

# OWNERS MANUAL FOR BARBECUE GAS GRILL

Model: CB4-SBC001-D

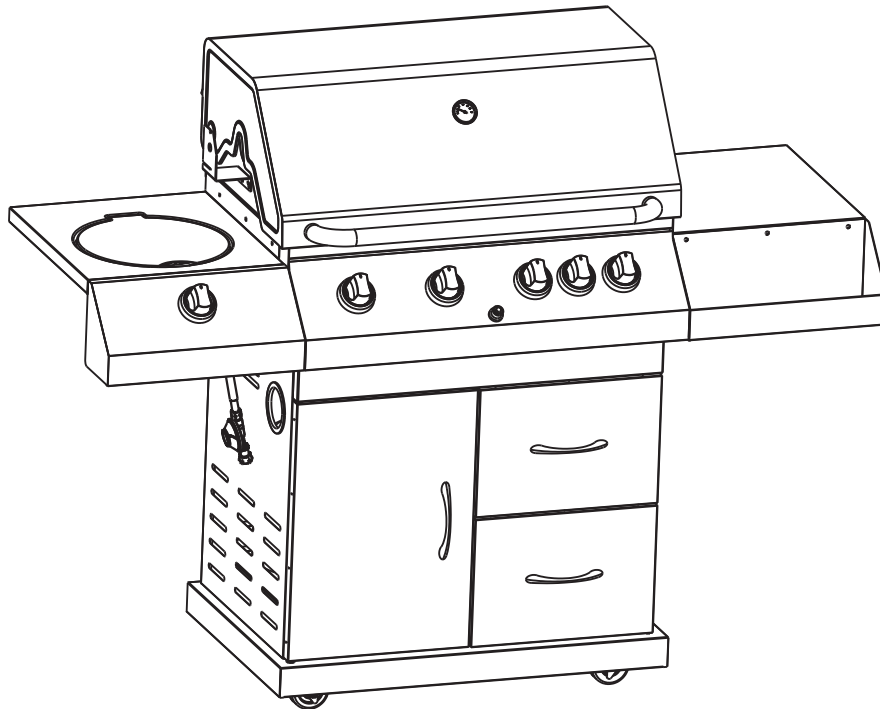

- ◆ IF A REPLACEMENT IS NECESSARY, PLEASE CONTACT EITHER OUR CUSTOMER SERVICE DEPARTMENT OR YOUR LOCAL DEALER.
- ◆ THE USE OF UNAUTHORISED PARTS CAN CREATE UNSAFE CONDITIONS AND ENVIRONMENT.
- ◆ FOR OUTDOOR USE ONLY.
- ◆ READ THE MANUAL CAREFULLY BEFORE ASSEMBLING AND USING THE APPLIANCE.
- ◆ ACCESSIBLE PARTS MAY BE VERY HOT. PLEASE KEEP YOUNG CHILDREN AND PETS AWAY.
- ◆ PLEASE RETAIN THE MANUAL FOR FUTURE REFERENCE.
- ◆ PLEASE REMOVE ANY TRANSIT PROTECTION BEFORE ASSEMBLING AND USING THE APPLIANCE.
- ◆ THIS APPLIANCE MUST BE KEPT AWAY FROM INFLAMMABLE MATERIALS
- ◆ PLEASE WEAR PROTECTIVE GLOVES WHEN HANDLING PARTICULARLY HOT COMPONENTS

## TECHNICAL INFORMATION

Model: CB4-SBC001-D (with side burner)

<b>APPLIANCE CODE:</b>	<b>CB4-SBC001-D</b>
<b>TEST POINT PRESSURE</b>	<b>2.75KPA</b>
<b>TOTAL NOMINAL GAS CONSUMPTION</b>	<b>83.30 MJ/H</b>
<b>NOMINAL GAS CONSUMPTION:</b>	<b>15.0 MJ/h Main Burner(X4) 11.0 MJ/h Side Burner 12.3 MJ/h back Burner</b>
<b>INJECTOR SIZE</b>	<b>1.12 mm for main burner 0.94 mm for side burner 1.02 mm for back burner</b>
<b>AGA APPROVAL NUMBER</b>	<b>AGA 7129 G</b>
<b>FOR USE OUTDOOR AND IN WELL VENTILATION AREAS</b>	
<b>WARNING: ACCESSIBLE PARTS MAY BE VERY HOT. KEEP YOUNG CHILDREN AWAY</b>	
<b>READ THE INSTRUCTION LITERATURE BEFORE USING THE APPLIANCE.</b>	
<b>*CLOSE THE VALVE OF THE GAS CYLINDER OR THE REGULATOR AFTER USE</b>	
<b>*THE USE OF THIS APPLIANCE IN ENCLOSED AREAS CAN BE DANGEROUS AND IS PROHIBITED.</b>	
<b>ALWAYS MAINTAIN 915MM MINIMUM CLEARANCE TO COMBUSTIBLE MATERIALS AT THE REAR AND SIDES OF THE BBQ . DO NOT USE THIS BBQ UNDER OVERHEAD COMBUSTABLE SURFACES.</b>	

(\* Injector size marked clearly on the burner valve)

**IGNITION:** Battery operated multi shot ignition unit (Battery not included)

**IMPORTANT:**

Read the following instructions carefully and be sure your barbecue is properly installed, assembled and cared for. Failure to follow these instructions may result in serious bodily injury and/or property damage.

If you have any questions concerning assembly or operation, consult your dealer or LPG Gas Company. Never store a spare cylinder under the barbecue shelves or inside the trolley housing. Any LPG cylinder not attached to the BBQ for use should be stored outdoors and well away from the appliance.

**⚠ WARNING**

**\* This appliance is not intended to use on recreational vehicles or a marine environment.**

**CLEARANCE TO COMBUSTIBLES**

Always maintain 915mm minimum clearance to combustible materials at the rear and sides of the BBQ.

Do not use this BBQ under overhead combustible surfaces.

# USE OUTDOORS ONLY

This appliance shall only be used in an above ground open-air situation with natural ventilation, without stagnant areas, where gas leakage and products of combustion are rapidly dispersed by wind and natural convection.

Any outdoor enclosure in which the appliance is used shall comply with one of the following:

- An enclosure with walls on all sides, but at least one permanent opening at ground level and no overhead cover. See Figure 1.
- Within a partial enclosure that includes an overhead cover and no more than two walls. See Figure 2 & 3.
- Within a partial enclosure that includes an overhead cover and more than two walls, the following shall apply:
  - At least 25% of the total wall area is completely open; and
  - At least 30% of the remaining wall area is open and unrestricted. See Figure 4 & 5.
- In the case of balconies, at least 20% of the total of the side, back and front wall areas shall be and remain open and unrestricted.

The following diagrams provide a diagrammatic representation of outdoor areas. Rectangular areas have been used in these figures - the same principles apply to any other shaped area

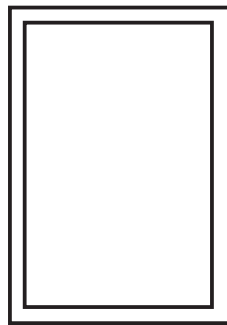
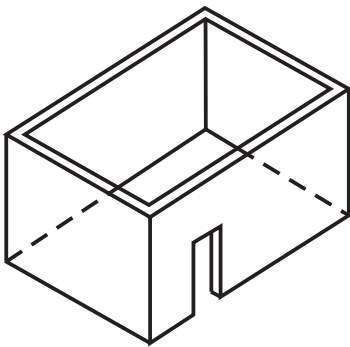

Figure 1 - Enclosure with walls on all sides but no overhead cover

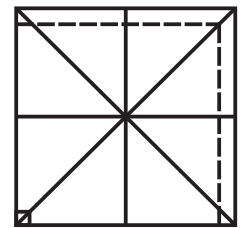
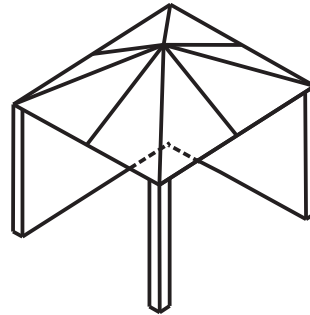

Figure 2 - Partial Enclosure with overhead cover and no more than two walls

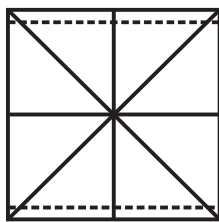
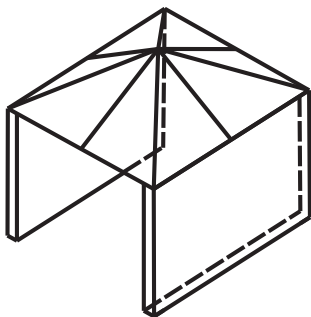

Figure 3 - Partial Enclosure with overhead cover and no more than two walls

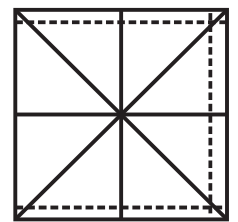
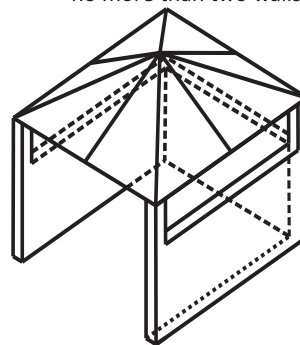

Figure 4 - Open side at least 25% of total wall area. 30% or more in total of the remaining wall area is open and unrestricted.

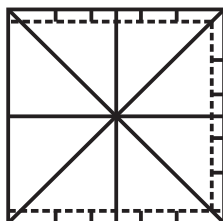
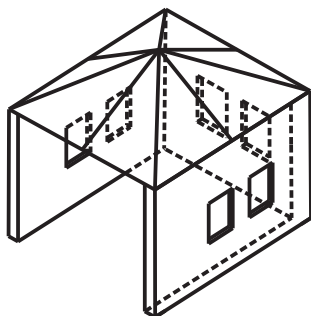

Figure 5 - Open side at least 25% of total wall area. 30 percent or more in total of the remaining wall area is open and unrestricted

**PART LIST**

NO	DESCRIPTION	QTY	NO	DESCRIPTION	QTY	
1		1	2		1/1	
3		4	4	 M6X10	20	
5		1	6		1	
7		1	8		1	
9		1	10		1	
11	 M8X10	 $\phi$ 8. 2	16	12		1
13		2	14		2	
15		1	16		1	
17		1				

\* Part list is for model CB4-SBC001-D please be subjected to the grill in your hand.

## EXPANDED VIEW

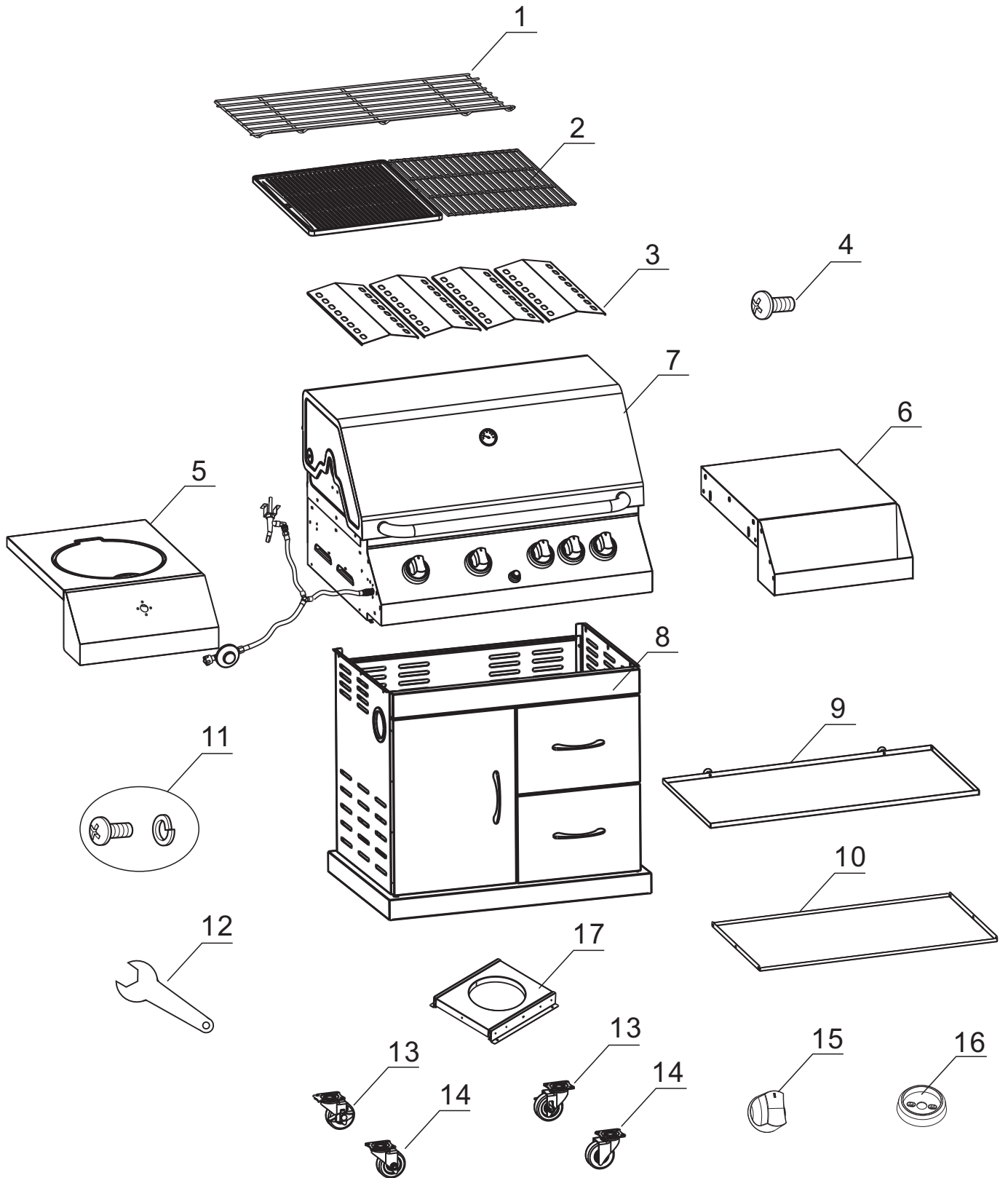

⌘ Part list is for model CB4-SBC001-D please be subjected to the grill in your hand.

## ASSEMBLY STEPS

### ⚠ CAUTION

Please take away all the packing and protecting material before assemble.

#### \* Tools Required

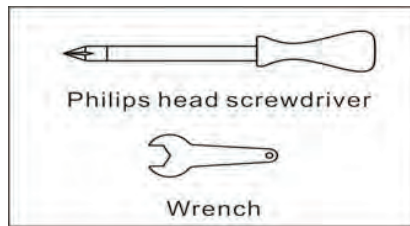

### \*1. Assemble wheels (No13.14) and the cylinder holder (No17).

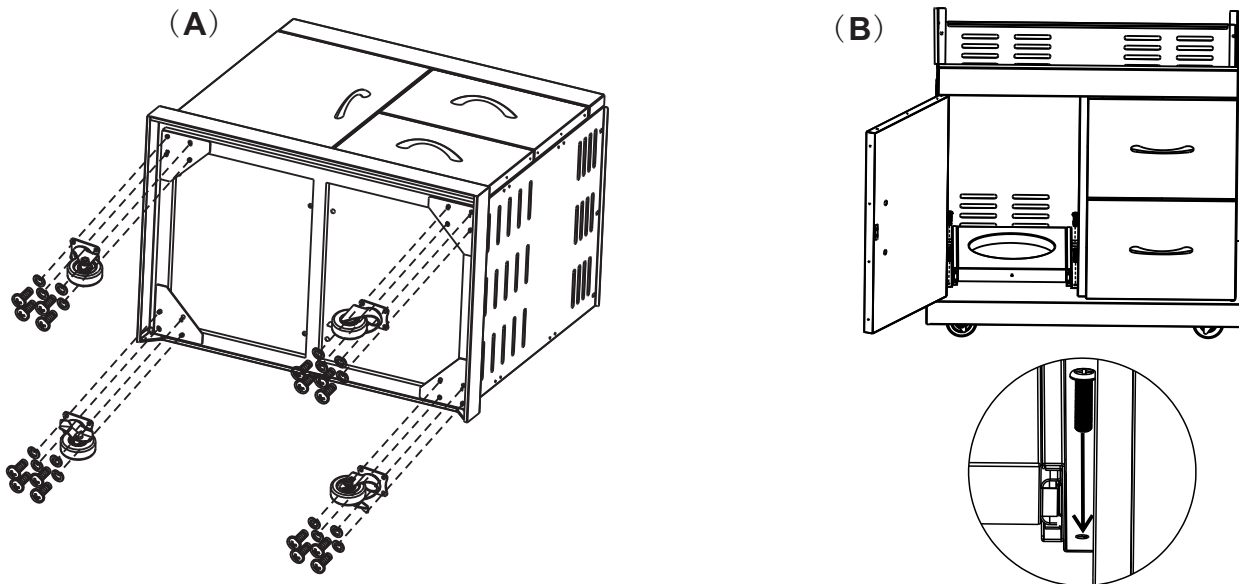

### \*2.

### ⚠ CAUTION

This step requires two persons to lift the main body (7) and position on the assembled cart. Carefully lower the main body (7) onto the cart (8). Insert the plate (10) into the main body(7), tighten and fix with 6pcs M6X10 crews.

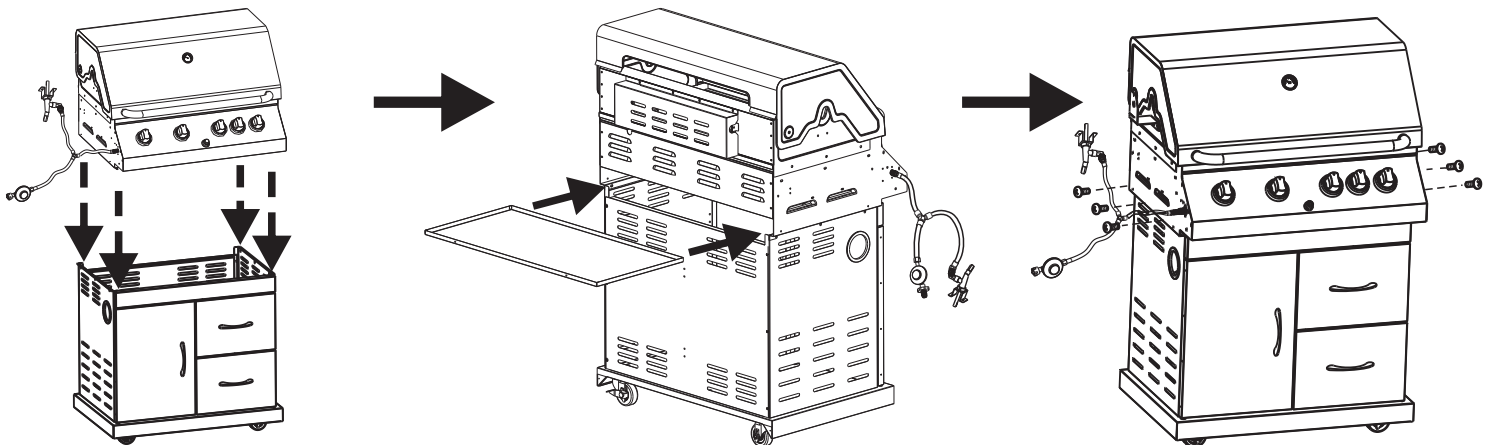

**\*3.**

Place right side shelf and left side burner over cart legs respectively. Tighten and fix with 4pcs M6X10 screws.

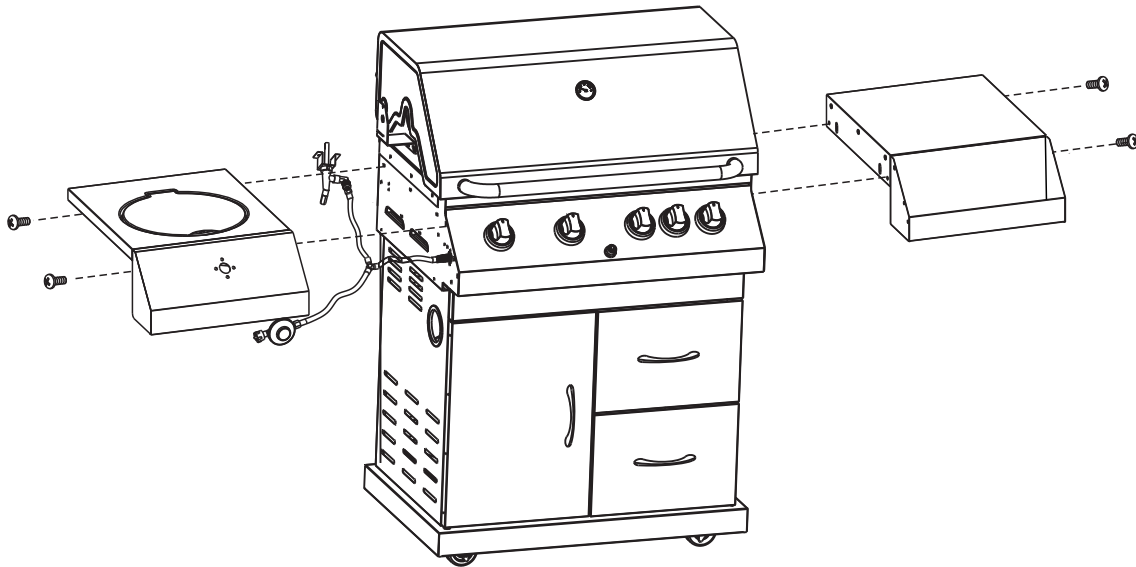

**(1) Assembly right side shelf**

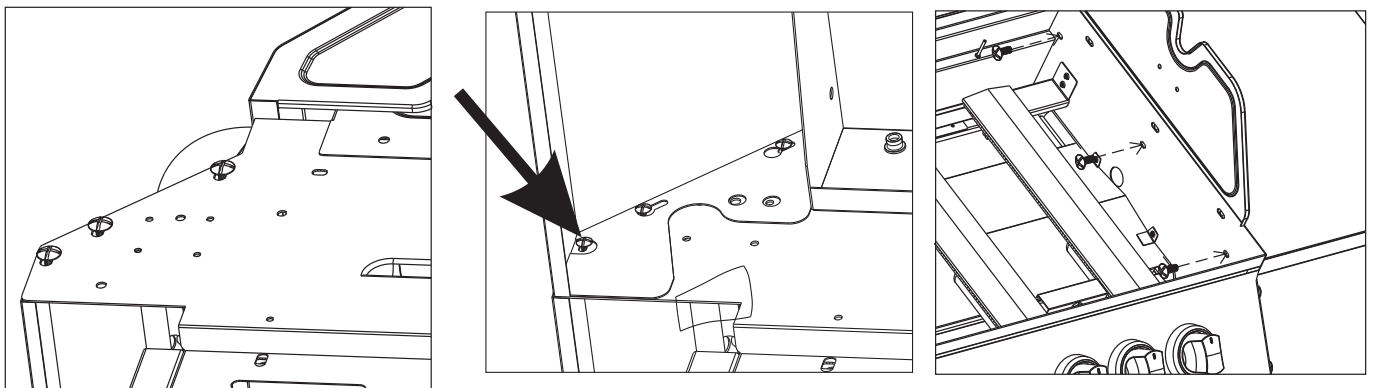

Loose the M4X8 screws on right side table which is pre-assembled, and hand the right side table assembly ( 6 ) on the screws and adjust to the position as showed , tighten the screws.

**(A) Loose 2 screws on the left side control Panel as showed**

**(B) Hand the side burner assembly ( 5 ) on the screws and adjust to the potion as showed, tighten the screws.**

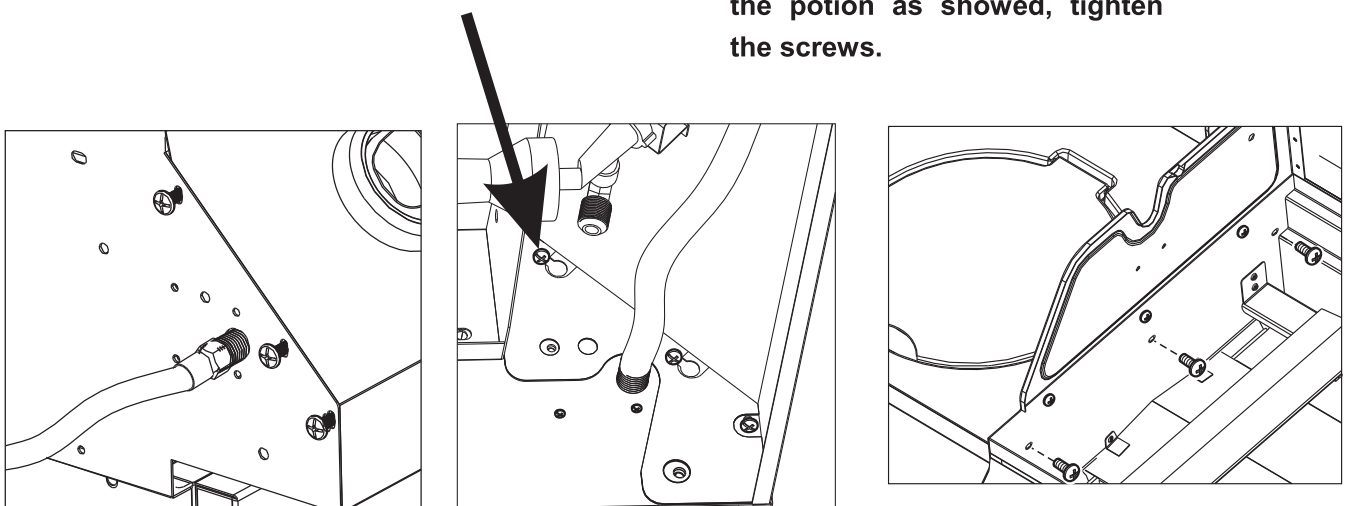



**\*4.**

Loosen the screws which secure the side burner with Philips head screwdriver and take it out.

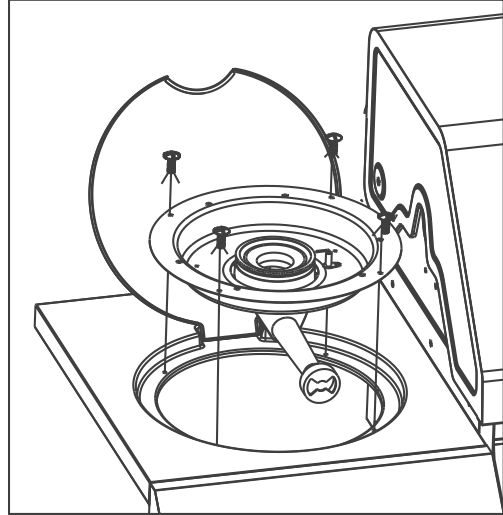
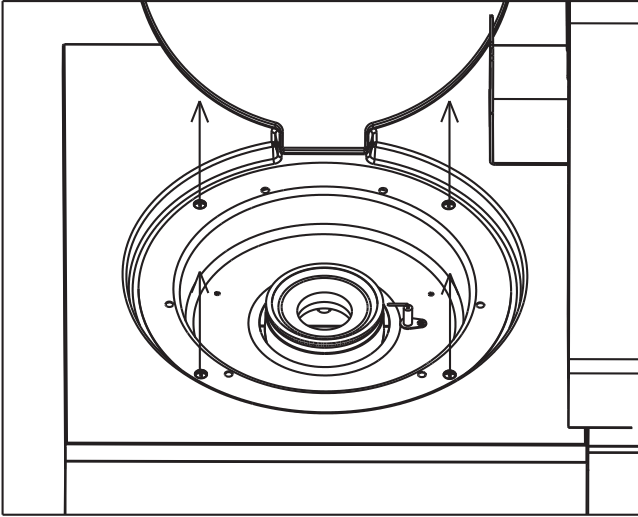

**\*5.**

Assemble the side valve, meanwhile put the knob seat on front panel and tighten the two screws together with knob seat and side valve.

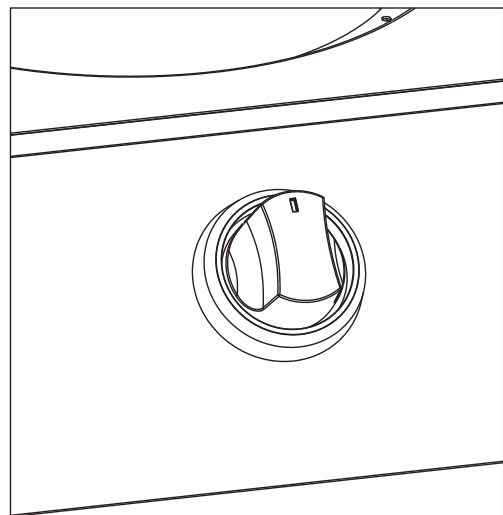
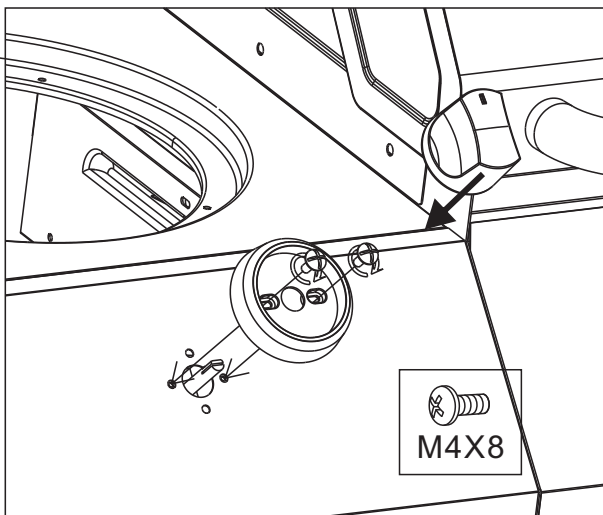
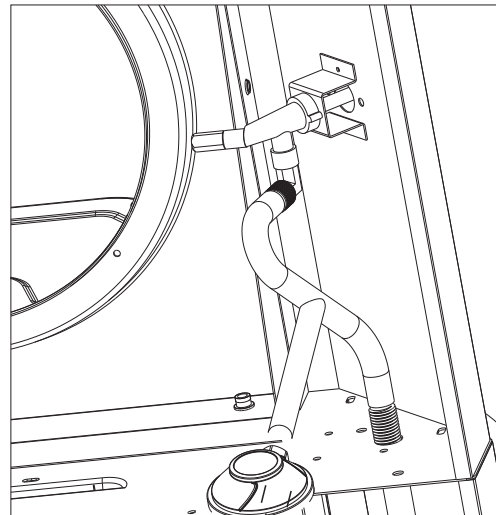
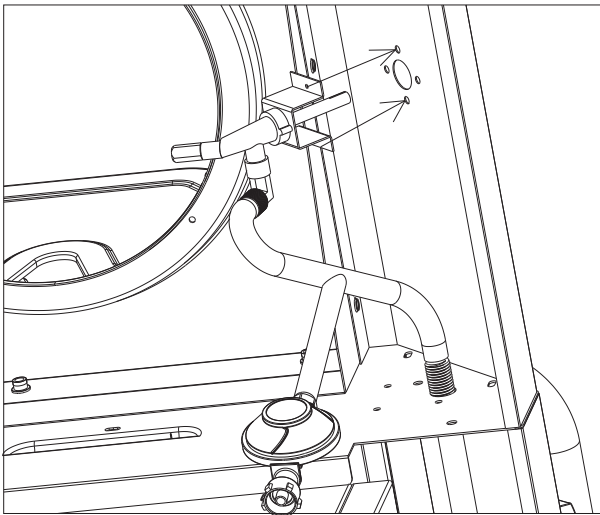

**\*6.**

Put back side burner and tighten the screws, meanwhile put the side burner inlet into side valve injector.

**⚠ WARNING**

**Make sure side burner inlet put into side valve injector.**

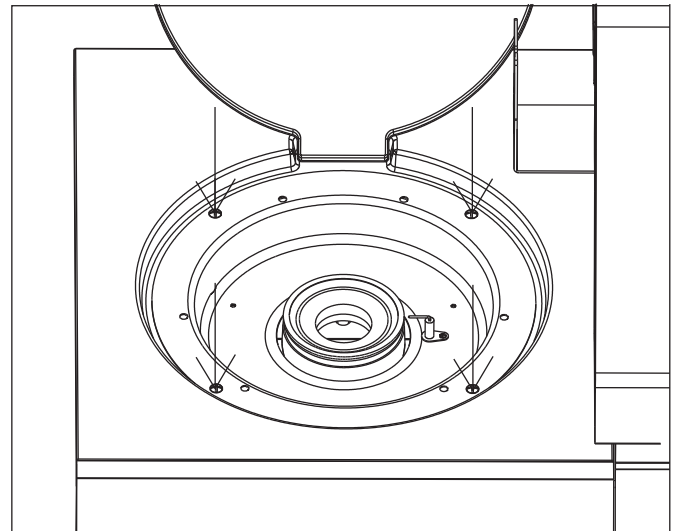
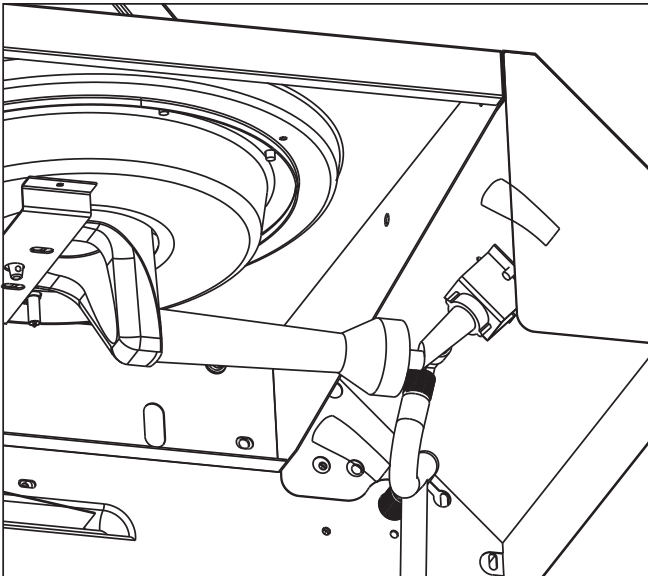
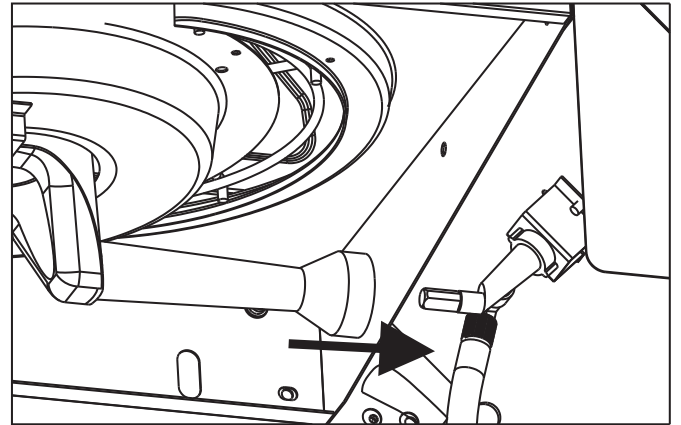
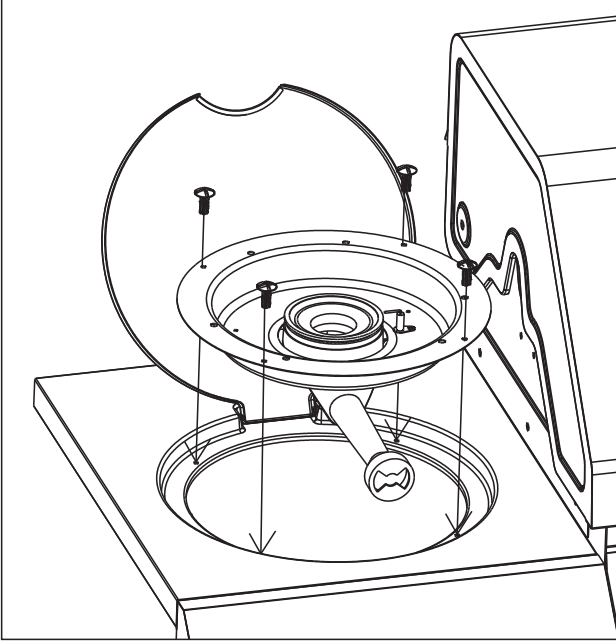

**\*7.**

**Connect the ignition wire to side burner**

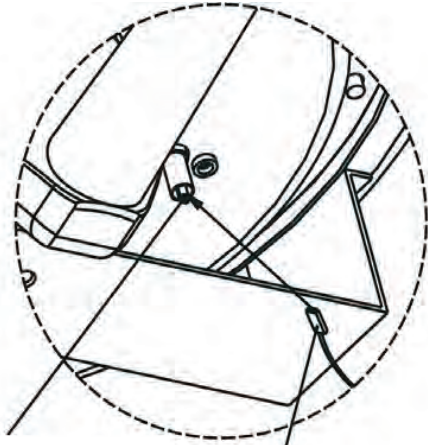

Side burner igniter lead

Electrode

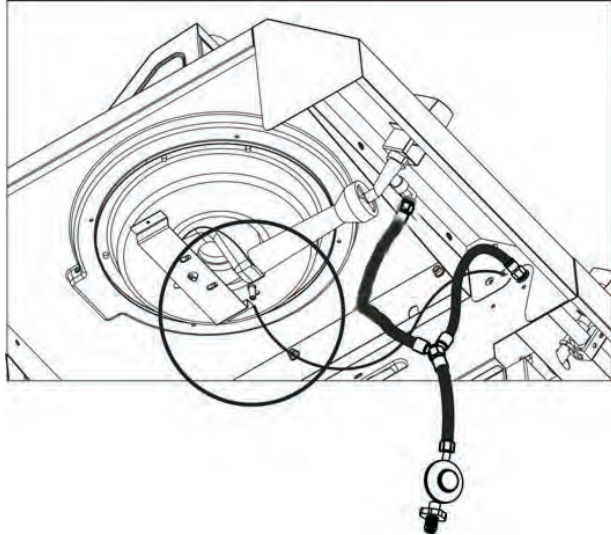

**\*8.**

**Place flame diffuser (3)**

**⚠ CAUTION**

- \* Burners already pre-assembled!
- \* Please take off the paper under burner before assembling flame distributor (No.3) and the first time of burning.

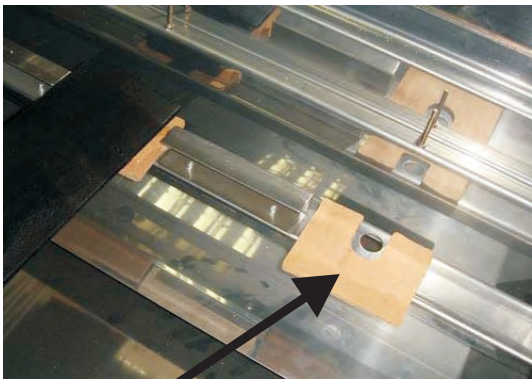
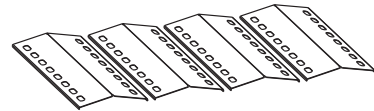

\*Paper under burner

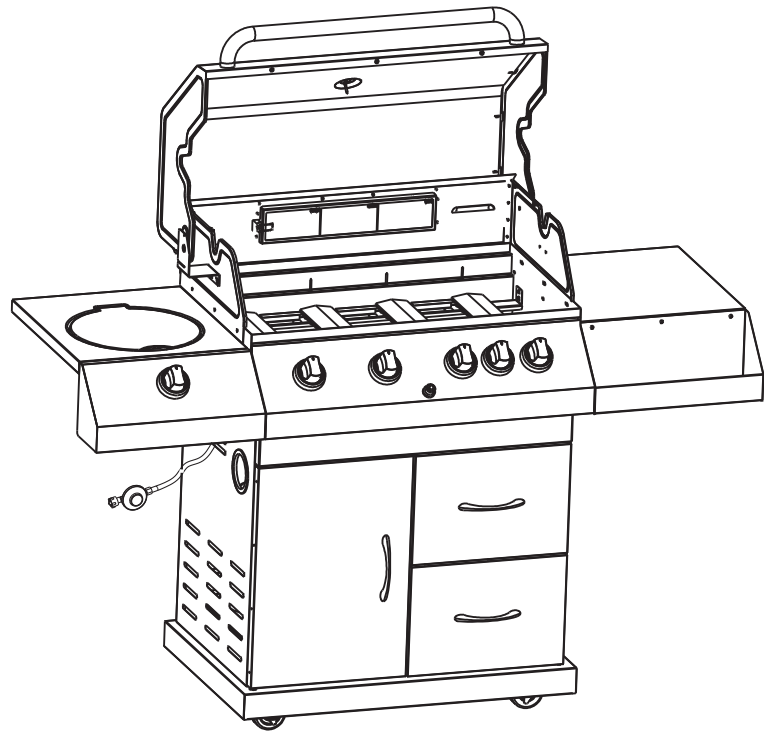

**\*9** Place cooking grids ( 2 ) into main body.

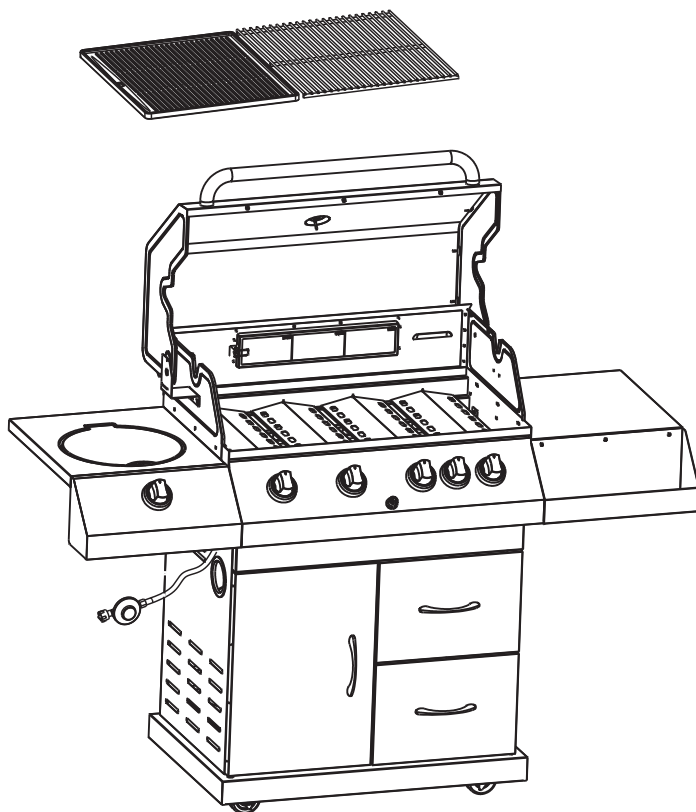
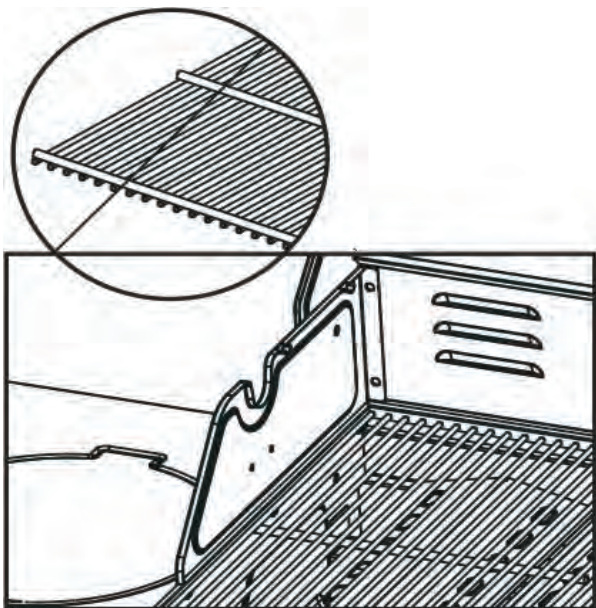

**\*10** Place warming rack ( 1 )

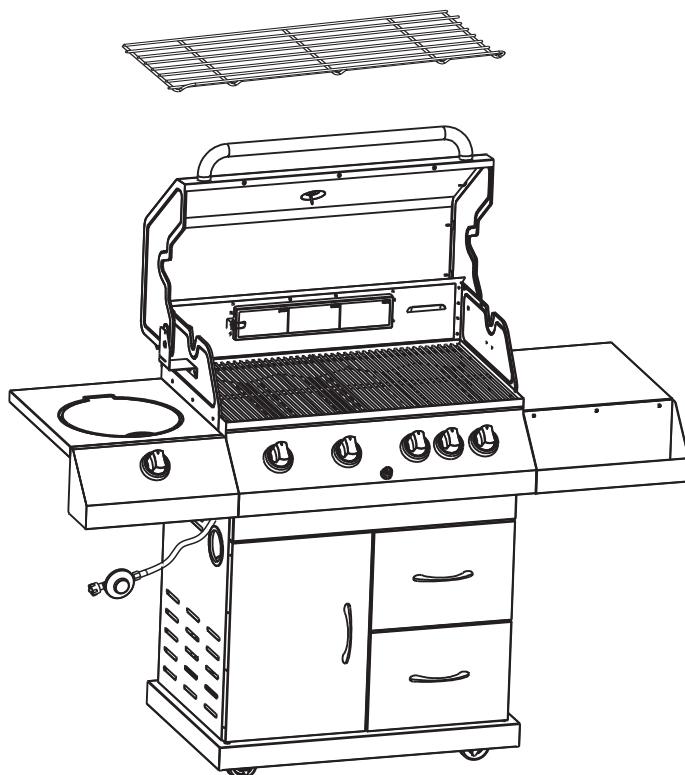
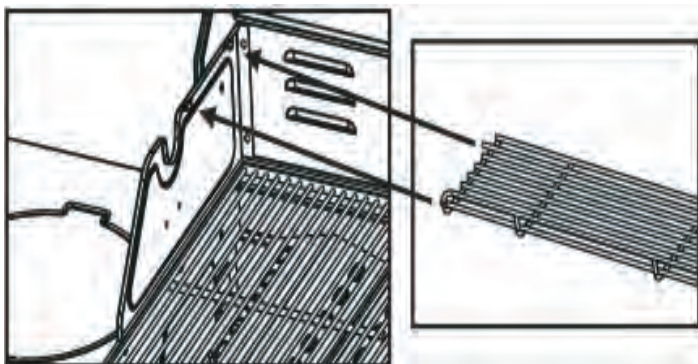

**\*11.** Place the grease tray ( 9)

**⚠ WARNING**

- \* This step is very important.
- \* Failed to place the possibly could cause fire accident.
- \* The grease tray is very hot during using, please do Not touch until it is cooled down.

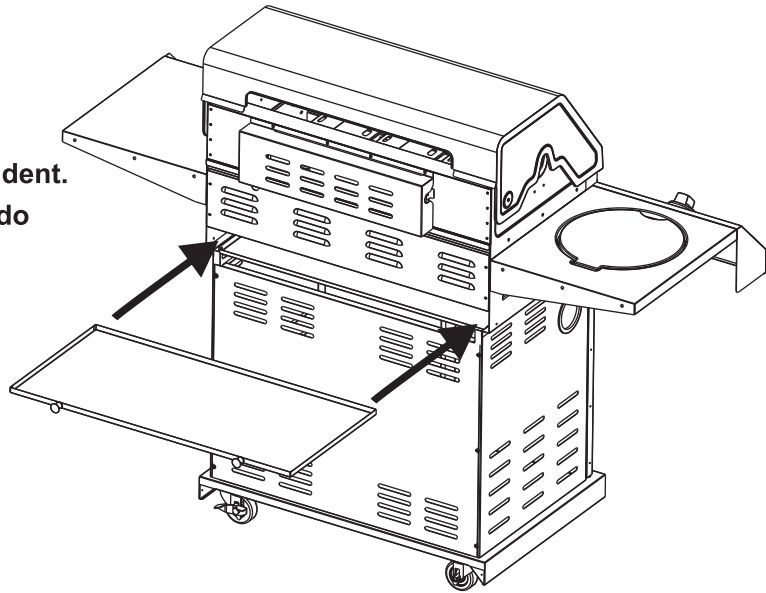

**\*12.** Put battery to operate the grill

- \* 1pc AA battery needed
- \* Battery not provided.

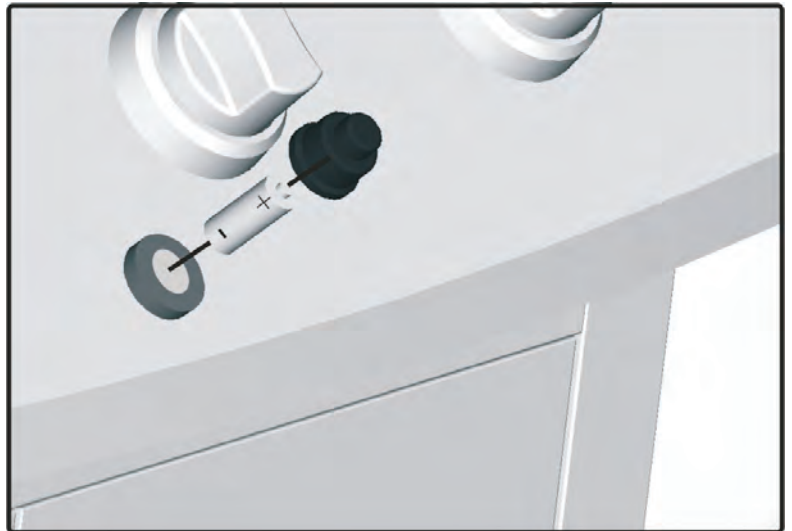

**\*13.** Match could be used to light on the grill

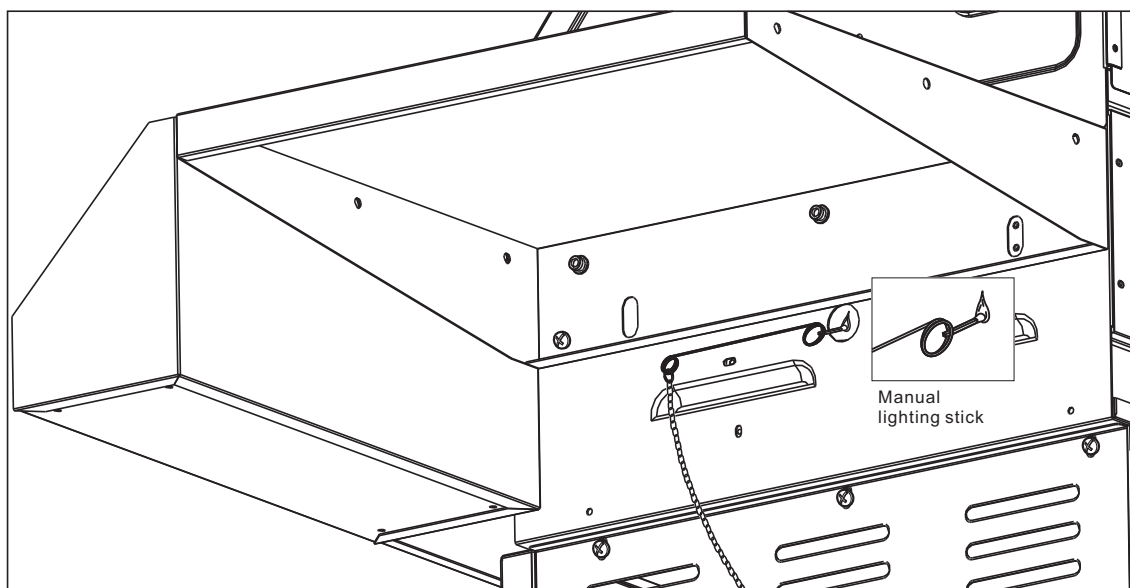

**\*14.** For model with infrared back burner

Model: CB4-SBC001-D

**▲ CAUTION**

\* The infrared back burner is only set for HIGH position.

\* DO NOT use the back burner with other grill burners at the same time.

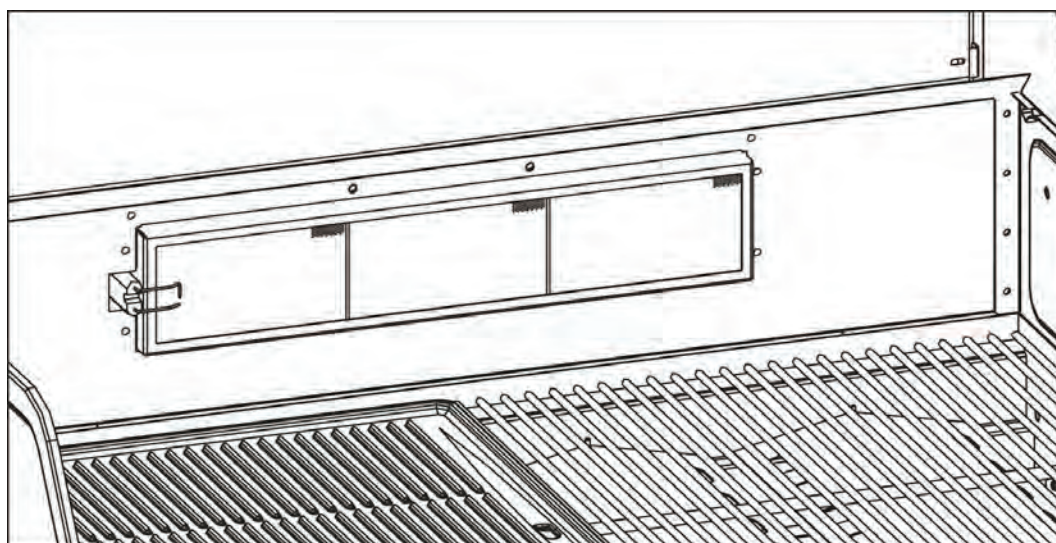

**\*15.** Instruction for replacing burners (if burner needed to be replaced):

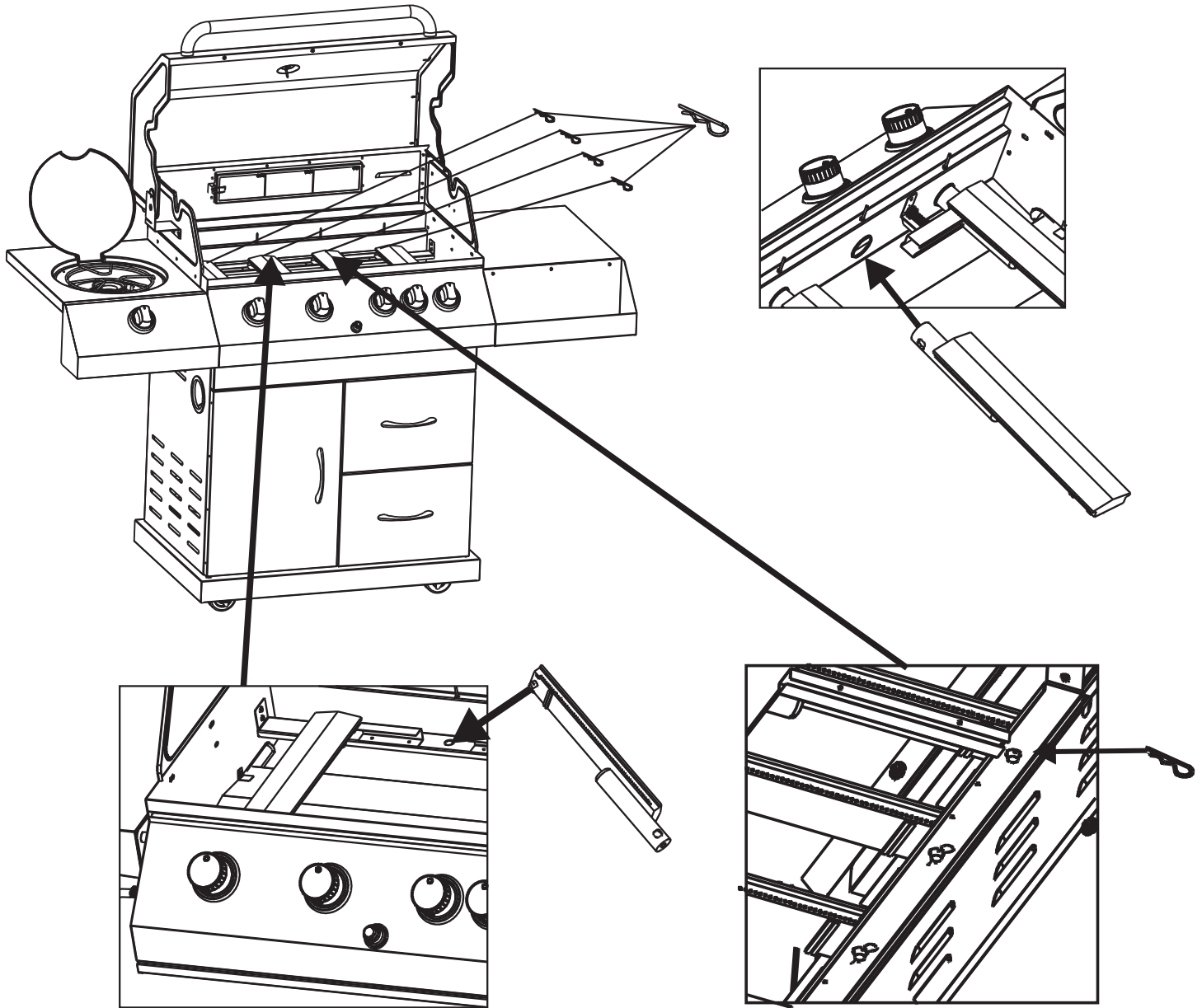

## USE AND CARE

### DO

- Use spanner to tighten all gas fittings
- Check all gas hose and line connection for damage, cuts or cracks each time for using the appliance.
- Always leak test with soapy water
- Check main burners regularly for insect nets such as spiders, ants, etc. Nets are dangerous and need to be fully cleaned.
- Use the appliance in ventilation areas
- Cool the appliance before replacing any lid or cover
- Accessible parts maybe very hot. Always Keep children away from the appliance
- Have the gas cylinder filled by an authorized Propane supplier
- Always wear protective gloves when handling hot components
- Close the gas cylinder valve after each use.
- Clean the grease tray regularly.
- Keep the appliance away from combustible material, gasoline, flame liquids or vapors.
- "Burning off" the barbecue after every use (for approx 15 minutes) will keep excessive food residue to a minimum.

### DO NOT

- Lean over appliance when lighting
- Leaving cooking food unattended
- Store combustible material, gasoline or flammable liquids or vapors within vicinity of barbecue
- Use appliance with any cover on
- Use plastic or glass utensils on the barbecue
- Use the appliance in strong winds
- Dismantle control valves
- Test for gas leaks with a naked flame
- Store spare gas cylinders in the cabinet
- Lay the gas cylinder down ( always keep upright)
- Use appliance indoors
- Modify the constructions of the appliance or the size of any burner, injector orifice or any other components
- Move the appliance during using
- Obstruct any ventilation of the appliance
- Allow the flexible gas supply hose or any electrical cord to come in contact with any heated surface of the appliance
- Use charcoal or any other solid fuel in this appliance
- Disconnect any gas fittings while the appliance is in using
- Use a rusty or dented gas cylinder with a damaged gas valve
- Fill the gas cylinder beyond 80% cap



**⚠ WARNING**

- ⌘ Should the burners extinguish for any reason, turn off all control knobs and the cylinder gas valve. Wait 5 minutes before attempting to relight the appliance.
- ⌘ If a grease or fat fire occur, turn off at an control knobs and gas cylinder valve immediately until the fire is out.
- ⌘ A leak test must be carried out prior to using the appliance for the first time or each time the gas cylinder is refilled or each time the gas hose and gas regulator being disconnected from the gas cylinders or appliance.



## Gas Cylinder Information

### Gas Cylinder Safety Information

This appliance is designed to be used with a gas cylinder not exceeding (Australia 9K G)

The gas cylinder supply valve must be turned off when the appliance is not in use.

Gas cylinders must be stored outdoors, out of reach of children and must not be stored in a building, garage or any other enclosed area.

The gas cylinder used must incorporate a safety collar to protect the valve assembly.

- \* Never store a spare cylinder under the barbecue shelves or inside the trolley housing. Any LPG cylinder not attached to the BBQ for use should be stored outdoors and well away from this appliance.

### Important:

When disconnecting and removing the gas cylinder for the purpose of refilling, always observe the following procedure .

Ensure that all gas control valves on the appliance and the gas cylinder are turned off before disconnecting the regulator from the cylinder.

Do not smoke or use a naked flame near the appliance or gas cylinder while disconnecting the gas line between the appliance and gas cylinder.

Remove the gas cylinder from the enclosure before disconnecting the regulator from the appliance.

Tighten all connections before placing the gas cylinder back in its enclosure.

The gas leak testing procedure should be conducted every time the gas cylinder is refilled and reconnected to the appliance before using the appliance.

### Regulator Connection

1. Check that all control knobs are in the Off position.
2. Make sure the cylinder valve is off.
3. Remove the protective cap from the cylinder if present.
4. Leak test the connection with a soapy water solution.

(See Gas Leak Testing Procedure)

## Gas Leak Test Procedure

Never use a naked flame to check for gas leaks. Always use the following procedure to check for gas leaks.

1. In a small container mix up a solution of water and detergent or soap. Mix the solution well.
2. Make sure that the gas supply valve on the gas cylinder is turned on.
3. Make sure that the gas control valve on the appliance are all turned off.
4. Using a brush or spray bottle apply the solution to the gas line and each joint in the gas line.
5. Bubbling of the solution will indicate that there is a leak present.
6. Re-tighten or re-seal any joints that are leaking.
7. If a leak persists then contact your distributor or the manufacturer for assistance.

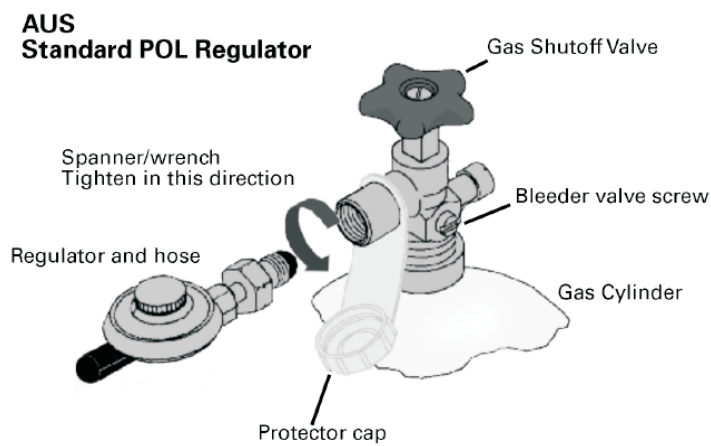



**For Safe Use Of Your Grill And To Avoid Serious Injury:**

- DO NOT** let children operate or play near grill.
- KEEP** grill area clear and free from material that burn.
- DO NOT** block holes in bottom or back of grill.
- Check burner flames regularly.**
- Use grill in well-ventilated space. NEVER use in enclosed spaces such as carport, garage, porch, covered patio, or under an overhead structure of any kind.**
- DO NOT** use charcoal or ceramic briquets in a gas grill. (*Unless briquets are supplied with your grill.*)

## **LIGHTING YOUR BARBECUE**

### **Lighting Instructions (Main grill burners):**

1. Turn the control knobs clockwise to “OFF” position.
2. Connect the regulator to the gas bottle. Turn the gas supply “ON” at the cylinder. Check with the use of soapy water for any gas leakage between the bottle and the regulator
3. Push down the front left control knob and keep pressing whilst turning anti-clockwise to the “Full rate” position and pressing the ignition button (a clicking sound is heard), this will light the left hand burner.  
  
If not, repeat this process.
4. If the burner still does not light, turn the control knob to 'OFF' wait 5 minutes and repeat step 3.
5. When the left hand burner is lit any of the remaining burners can be lit by repeating operations 3 and 4. Your barbecue either has 3, 4 or 5 main burners which can be used together or in any combinations of burners.
6. Adjust the heat by turning the knob to the High/Low position.
7. To turn the barbecue ‘OFF’ turn the cylinder valve to the ‘OFF’ position and then turn all of the control knobs on the barbecue clockwise to the ‘OFF’ position.

### **Lighting Instructions (Side burner):**

1. Turn the control knob clockwise to "OFF" position.
2. Connect the regulator to the gas bottle. Turn the gas supply "ON" at the cylinder. Check with the use of soapy water for any gas leakage between the bottle and the regulator
3. Push down the side burner control knob on the side burner shelf and keep pressing whilst turning anti-clockwise to the "Full rate" position whilst also pressing the ignition button and (a clicking sound is heard), this will light the side burner. If the burner does not light repeat this process.
4. If the burner still does not light, turn the control knob to 'OFF' wait 5 minutes and repeat step 3.
5. When the side burner is lit, place the pot over the burner.
6. Adjust the heat by turning the knob to the High/Low position.

#### **⚠ CAUTION**

- |  |
|--|
| <ol style="list-style-type: none"><li>1. Never light or use the side burner with the lid in the closed position.</li><li>2. Never attempt to light the side burner with a pot over the burner. Light the burner first, and then place the pot over the burner.</li></ol> |
|--|

### **Lighting Instructions (Rear burner):**

1. Read and follow all of warnings and instructions in owner's manual before lighting
2. Open Grill Hood before lighting rotisserie burner
3. Make sure control knob is in the "OFF" position
4. Push and turn the Back Burner control knob to the high position. Continue to push in control knob while pressing electronic igniter for more than 5 seconds.
5. Once burner is lit, continue to push and hold control knob for 30 seconds.
6. If ignition does Not occur in 5 seconds, turn control knob to "OFF" , Wait 5 minutes to allow gas to dissipate and repeat lighting procedure.
7. To turn off, turn control knob clockwise until it locks in the "OFF" position.
8. The back burner is only set for "HIGH"position.

**IMPORTANT: DO NOT USE MAIN BURNERS AND BACK BURNER AT THE SAME TIME.**

#### **⚠ WARNING**

If the rear burner fails to remain alight or the flame pattern is disturbed, ensure it is not facing into a direct wind. Re-position the direction of the BBQ, wait 5 minutes, and try the lighting procedure again.

#### **⚠ WARNING**

If any burner fails to ignite, turn the control knob off (clockwise) and also turn the cylinder valve off. Wait five minutes before attempting to relight with ignition sequence.

#### **⚠ WARNING**

DO NOT USE THE REAR BURNER WHILE OTHER GRILL BURNERS ARE IN OPERATION.

Before cooking for the first time, operate the barbecue for about 15 minutes with the lid closed and the gas turned on HIGH. This will heat clean the internal parts and dissipate odor from the painted finish. (The color of cooking area may get little change. It is normal and It is the nature of material)

#### **⚠ CAUTION**

Clean your barbecue after each USE. **DO NOT** use abrasive or flammable cleaners, as it will damage the parts of the product and may start a fire. Clean in warm soapy water.

### **ABNORMAL OPERATION**

Any of the following are considered to be abnormal operation and may require servicing:

- Yellow tipping of the burner flame.
- Sooting up of grill plates.
- Burners not igniting properly.
- Burners failing to remain alight.
- Burners extinguished by trolley doors.
- Gas valves, which are difficult to turn.

### **CLEANING AND CARE**

This appliance should be checked and serviced by an authorised service person every year to ensure the appliance remains in a safe operation condition.

#### **⚠ CAUTION**

All cleaning and maintenance should be carried out when the barbecue is cool and with the fuel supply turned **OFF** at the gas cylinder.

DO NOT remove the drip tray until the BBQ has cooled.

### **General Grill Cleaning**

- DO NOT mistake brown or black accumulation of grease and smoke for paint. Interiors of gas grills are not painted at the factory (and should NEVER be painted). Apply a strong solution of detergent and water or use a grill cleaner with scrub brush on insides of grill lid and bottom. Rinse and allow to completely air dry. DO NOT apply a caustic grill / oven cleaner to painted surfaces.
- Plastic parts: wash with warm soapy water and wipe dry.

- ▲ DO NOT use abrasive cleaners, degreasers or a concentrated grill cleaner on plastic parts. Damage to and failure of parts can result.
- Porcelain surfaces: because of glass-like composition, most residue can be wiped away with backing soda / water solution or specially formulated cleaner. Use nonabrasive scouring powder for stubborn stains.
- Painted surfaces: wash with mild detergent or nonabrasive cleaner and warm soapy water. Wipe dry with a soft nonabrasive cloth.
- Stainless steel surfaces: to maintain your grill's high quality appearance, wash with mild detergent and warm soapy water and wipe dry with a soft nonabrasive cloth after each use. Backed-on grease deposits may require the use of an abrasive plastic cleaning pad.



### NATURAL HAZARD SPIDERS

**FACT: sometimes spiders and other insects climb into the grill tubes attached to the burners. The spiders spin webs, build nests and lay eggs. The webs or nests can be very small, but they are very strong and can block the flow of gas. Clean burners prior to use after storing, at the beginning of grilling season or after a period of one month not being used.**



**Spider guards are on the air intakes in an effort to reduce this problem, but it will not eliminate it! An obstruction can result in a “flashback”(a fire in the burner tubes). The grill may still light, but the obstruction does not allow full gas flow to the burners.**

**Follow these instructions to clean and / or replace parts of burner assembly or if you have trouble igniting grill.**

1. Turn gas off at control knobs and LP Tank.
2. Remove cooking grates, grease tray and grease cup.
3. Remove cotter pins from beneath each burner “foot” using a screwdriver or needle nose pliers.
4. Carefully lift each burner up and away from valve openings.

We suggest three ways to clean the burner tubes. Use the one easiest for you.

- (A) Bend a stiff wire( a light weight coat hanger works well) into a small hook. Run the hook through each burner tube and burner several times.



- (B) Use a narrow bottle brush with a flexible handle (DO NOT use a brass wire brush), run the brush through each burner tube and burner several times.

- (C) Wear eye protection: use an air hose to force air into the burner tube and out the air ports. Check each port to make sure air comes out each hole.
5. Wire brush entire outer surface of burner to remove food residue and dirt.
  6. Clean any blocked ports with a stiff wire such as an open paper clip.
  7. Check burner for damage, due to normal wear and corrosion some holes may become enlarged. If any large cracks or holes are found replace burner.

**VERY IMPORTANT: Burner tubes must reengage valve openings. See instructions below.**

8. Carefully replace burners.
9. Replace cotter pin beneath each burner.
10. Replace grease tray, grease cup, and cooking grates.

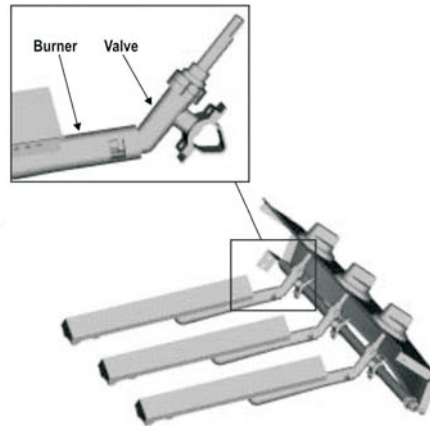

---

### **Outside surface**

Use mild detergent or baking soda and hot water solution. Non-abrasive scouring powder can be used on stubborn stains, then rinse with water.

If the inside surface of the barbecue lid has the appearance of peeling paint, baked on grease build-up has turned to carbon and is flaking off. Clean thoroughly with strong hot soapy water solution. Rinse with water and allow to completely dry. **NEVER USE OVEN CLEANER.**

### **Interior of Barbecue bottom**

Remove residue using brush, scraper and/or cleaning pad then wash with a soapy water solution. Rinse with water and allow to dry.

## **Cooking Grid**

Use a mild soapy water solution. Non-abrasive scouring power can be used on stubborn stains then rinse with water.

## **Cleaning the burner assembly**

Turn the gas OFF at the control knob and disconnect the cylinder.

Remove cooling grate.

Clean the burner with a soft brush or blow clean with compressed air and wipe with a cloth.

Clean any clogged ports with a pipe cleaner or stiff wire (such as an opened paper clip).

**⚠ CAUTION** Inspect burner for any damage (cracks or holes). If damage is found, replace with a new burner. Reinstall the burner, check to ensure that the Gas valve orifices are correctly positioned and secured inside the burner inlet (venturi).

## **SERVICING & SPARE PARTS**

Your gas barbecue should be serviced annually by a competent registered person

Contact Details of distributors in case of any faults, problems in assembly or use:

K&P AU Pty Ltd

Email: [support@kpleisure.com.au](mailto:support@kpleisure.com.au) <mailto:support@kpleisure.com.au>

Web: [www.kpleisure.com.au](http://www.kpleisure.com.au) <http://www.kpleisure.com.au>

Address: 39/24 Garling Road, Kings Park, NSW 2148



## Troubleshooting

Problem	Possible Cause	Prevention/Solution
Burner(s) will not light using ignitor.	• Wire and/or electrode covered with cooking residue.	• Clean wire and/or electrode with rubbing alcohol and clean swab.
	• Electrode cracked or broken "sparks at crack".	• Replace electrode(s).
	• Electrode tip not in proper position.	• Reconnect wires or replace electrode/wire assembly.
	• Wires are loose or disconnected. • Wires are shorting (sparking) between ignitor and electrode.	• Replace ignitor wire/electrode assembly.
	• Dead battery.	• Replace with a new AA battery.
Burner(s) will not match light.	• No gas flow.	• Check to see if LP tank is empty. If LP tank is not empty.
	• Coupling nut and regulator not fully connected.	Turn the coupling nut about one-half to three quarters additional turn until solid stop. Tighten by hand only-do not use tools.
	• Obstruction of gas flow.	• Clear burner tube(s).
	• Disengagement of burner to valve.	• Reengage burner and valve.
	• Is grill assembled correctly?	• Check steps in assembly instructions.
Sudden drop in gas flow or low flame.	• Out of gas.	• Check for gas in LP tank.
	• Excess flow valve tripped.	Turn off knobs, wait 30 seconds and light grill. If flames are still low, turn off knobs and LP tank valve. Disconnect regulator. Reconnect regulator and leak test. Turn on LP tank valve, wait 30 seconds and then light grill.
Flames blow out.	• High or gusting winds.	• Turn front of grill to face wind or increase flame height.
	• Low on LP gas.	• Refill LP tank.
Flare-up.	• Grease buildup.	• Clean grill.
	• Excessive fat in meat.	• Trim fat from meat before grilling.
	• Excessive cooking temperature.	• Adjust (lower) temperature accordingly.
Persistent grease fire.	• Grease trapped by food buildup around burner system.	• Turn knobs to OFF. Turn gas off at LP tank. Leave lid in position and let fire burn out. After grill cools, remove and clean all parts.
Flashback... (fire in burner tube(s)).	• Burner and/or burner tubes are blocked.	• Turn knobs to OFF. Clean burner and/or burner tubes.
Unable to fill LP tank.	• Some dealers have older fill nozzles with worn threads.	• The worn nozzles don't have enough "bite" to engage the valve. Try a second LP dealer.

## Troubleshooting-Electronic Ignition

Problem	Possible Cause	Check Procedure	Prevention/Solution
No sparks appear at any electrodes when ignition button is pushed; no noise can be heard from spark module.	·Battery not installed properly.	·Check battery orientation	·Install battery(make sure that “+” and “-” connectors are oriented correctly, with “+” end up and “-” end down.
	Dead battery	Has battery been used previously?	Replace battery with new AA-size alkaline battery.
	Button assembled not installed properly.	Check to insure threads are properly engaged. Button should travel up and down without binding.	Unscrew button cap assembly and reinstall, making sure threads are aligned and engaged fully.
	Faulty spark module.	·If no sparks are generated with new battery and good wire connections, module is faulty.	Replace spark module assembly.
No sparks appear at any electrodes when ignition switch is pushed; noise can be heard from spark module.	·Output lead connections not completed.	·Are output connections on and tight?	·Remove and reconnect all output connections at module and electrodes.
Sparks are present but not at all electrodes and/or not at full strength.	·Output lead connections not complete.	·Are output connections on and tight?	·Remove and reconnect all output connections at module and electrodes.
	·Arcing to grill away from burner(s)	·If possible, observe grill in dark location. Operate ignition system and look for arcing between output wires and grill flames.	·If sparks are observed other than from burner(s), wire insulation maybe damaged. Replace wires.
	·Weak battery	·All sparks present but weak or at slow rate.	·Replace battery with a new AA-size alkaline battery.
	·Electrodes are wet	·Has moisture accumulated on electrode and/or in burner ports?	·Use paper towel to remove moisture.
	·Electrodes cracked or broken “sparks at crack”	·Inspect electrodes for cracks.	·Replace cracked or broken electrodes.