



Kids Electric Ride-On AC Cobra Replica

User Manual

[Revision 5.0 January 2018]

READ THIS MANUAL CAREFULLY BEFORE USE – FAILURE TO DO SO MAY RESULT IN INJURY, PROPERTY DAMAGE AND MAY VOID WARRANTY. • KEEP THIS MANUAL FOR FUTURE REFERENCE. • Products covered by this manual may vary in appearance, assembly, inclusions, specifications, description and packaging.

THE BATTERY MAY HAVE SOME CHARGE ON ARRIVAL, IT IS IMPORTANT HOWEVER THAT THE BATTERY IS CHARGED PRIOR TO USE.



Table of Contents

Safety	1
Charging	1
Additional Reminders	2
Remote	2
Assembly	3
Operation	5
Maintenance	7
Technical Specifications	7



Kids Ride-on Car

Safety

Please keep and read the instructions carefully before using to reduce the chances of hurting your child and damaging the car.

The pictures in this user manual are intended to show the user the operating method of the car. If there are any discrepancies in the pictures and the car, please take the car as a standard.

Please read the instructions carefully before using the car. It will teach you the right way of operating the car and installing parts, in case that incorrect operations may cause damage to the car or hurt your child. Please keep this user manual for safekeeping.

For your child's safety, please pay attention to the following safety warnings:

- This toy is unsuitable for children under 3 years of age due to its maximum speed.
- Protective equipment should be worn. Should not be used in traffic.
- Installation should be done by adults; keep your child away from moving parts.
- Not suitable for children less than 36 months of age because of small parts inside.
- Make sure to use the safety belt correctly when driving; keep away from fire!
- Children cannot drive alone without adults supervising them.
- Do not let your child stand on the step board (or in the car).
- After charging the battery by adults, your child can then use the car.
- Put plastic bags away from your child to reduce the risk of suffocation.
- Do not use any spare parts that are not officially produced by the manufacturer.
- All batteries should be placed in their correct polarity (+ to +, - to 0).
- Do not make the charger into a toy.
- Do not load more than 30kg on the car.
- Suitable ages for the car is 37-96 months.
- Non-storage battery cannot be charged; take the exhausted battery out.
- Do not mix old, new or different kinds batteries together.
- Do not allow the power terminal to short-circuit.
- The car is not allowed to be charged more than what is recommended.

Charging

- Make sure the battery has been charged over 18 hours before first use.
- Connect the charger DC plug, and then connect the charger into the power supply.
- Do not operate the car when charging.
- After 1 hour of use, you should charge in time. It takes 8-12 hours to charge normally.
- Do not charge for more than 20 hours.



Kids Ride-on Car

- It is normal for heat to be released from the charger and battery when it is charging lower than 60 degrees Celsius.
- Charging in wet conditions can cause short-circuiting.
- Make sure to use the self-containing charger & batter to avoid any damage to the circuitry. Charge the battery once a month when car is not being used for a long time.

Additional Reminders

- Make sure the battery has been charged for over 18 hours before first use, otherwise it will be permanently damaged.
- Do not drive the car on slippery streets, roads, slopes or other dangerous places.
- Do not drive the car on smooth surfaces, such as marble and floor tiles.
- Do not transfer the switch to “go forward” to “go back” when driving.
- Do not allow your child to stand on the seat.
- Do not make any changes to the circuitry or other electronic devices.
- Keep the remote control and the car away from rain, water and fire.
- Do not soak water or any other liquids on the car to avoid damaging the circuitry.
- When the car meets an obstacle, it will automatically stop. You can continue driving after getting past the obstacle.
- Do not drive the car indoors to avoid damaging furnitures or getting your child in an accident.
- When the power is low, the car can just go forward, but not left or right.
- When it cannot go further or it is shaking, etc., please change the battery at once.
- The car can carry one child only with a maximum weight of 30kg.
- Please turn off the power when not in use. If the car is not driven for a long time, please cut off the battery connector.

Remote

- Please fit two AA 1.5V batteries into the remote battery holders, with the positive and negative pole positioned correctly.
- Please remove used batteries from the battery holders.
- Please take the batteries out if the car will not be used for long time.
- Do not expose the remote control in water/damp environments.
- Do not mix old, new or different kinds batteries together.
- Please check the electrical wires and other parts regularly. If damaged, do not use.
- Do not allow the power terminal to short-circuit.
- The batteries are not toys, which should be assembled by an adult.
- Do not allow your child to open or change the batteries by himself.

Assembly

1. Installing the wind guard and rear view mirror
 - a. Install the wind guard: put the wind guard into the recess hole.
 - b. Install the rear view mirror: put the rear view mirror into the recess hole

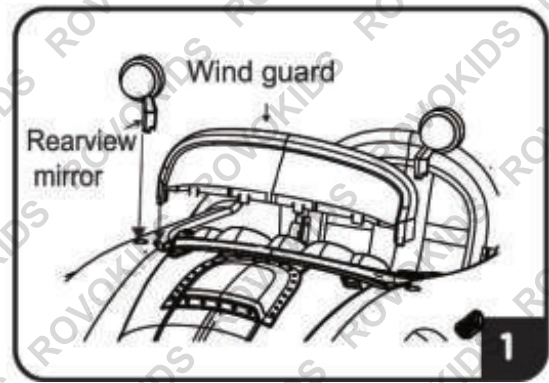

Video Tutorial:

[Typical Ride-On Car Assembly](#)



2. Installing the motor cover
 - a. connect the power while following the mark on the storage battery
 - b. fix (a) and (b) firmly
 - c. turn (c) knob according to the arrow to lock the motor cover

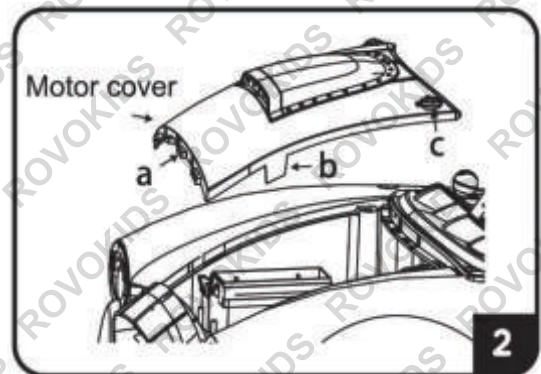

3. Installing the steering wheel
 - a. connect the wire for the steering and panel board
 - b. fix the steering rod

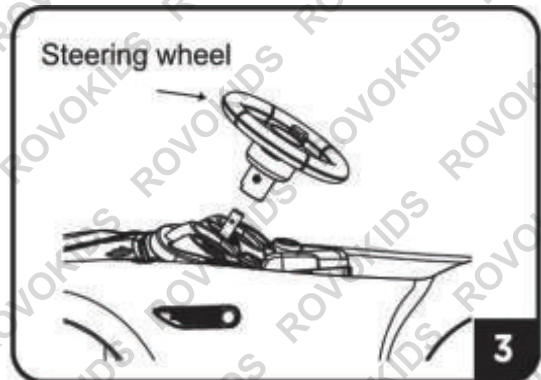

4. Installing the front wheel
 - a. install shim (1 pc) on the front wheel axle
 - b. install the front wheel
 - c. install shim (1 pc)
 - d. insert the cotter pin and bend up the end
 - e. fix the front wheel cover

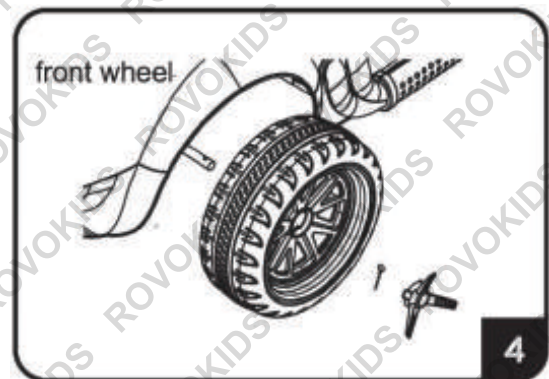

Kids Ride-on Car

5. Installing the back wheel
 - a. fix (a) the rear wheel axle
 - b. put the gear box into the axle and motor hole
 - c. fix the back wheel
 - d. bend up the longer end, and then insert (e)

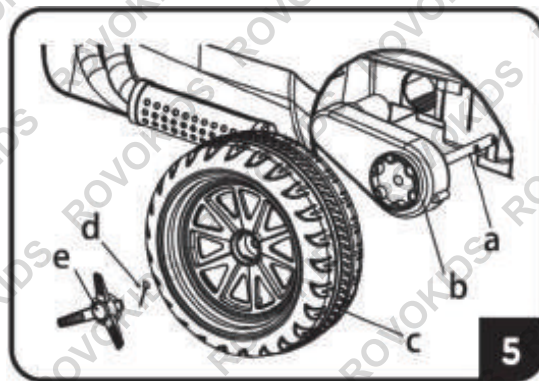

6. Installing the seat
 - a. connect the motor drive wire and the control wire under the seat
 - b. insert the clip of both side of seat (a) into recess hole
 - c. turn (b) according to the arrow to lock the seat
7. Installing the back rest tube
 - a. put (c) into the recess hole while pressing the spring pin

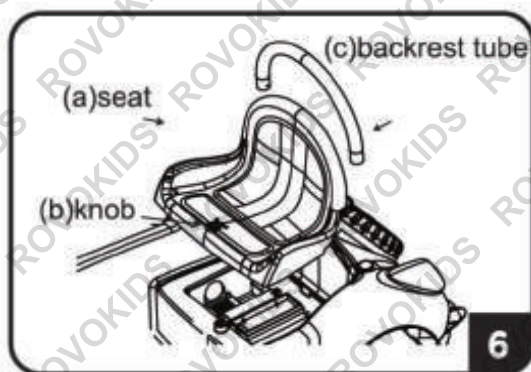

NOTE: Please remove the terminal cover first when assembling the battery (see image below).



Operation

1. When the power is low, please charge on time.

The charging plug hole is in the lower right the panel board (above the pedal).

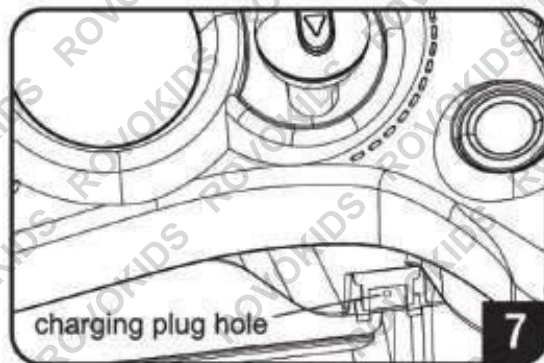

2. Let your child sit safely on the car and turn on the power.

When it is in manual control mode, press the pedal and you can go forward or backward while using the "go forward and backward" gear shift lever.

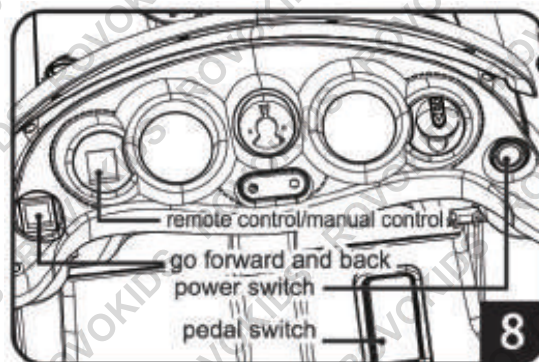

3. When it is in remote control mode, use the remote control to make the car go forward and backward or turn it left and right.

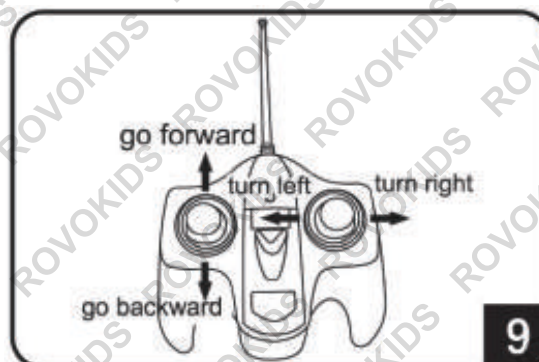

4. Battery for remote control: put 2 pieces of AAA 1.5V batteries into the battery box with correct positive and negative poles.

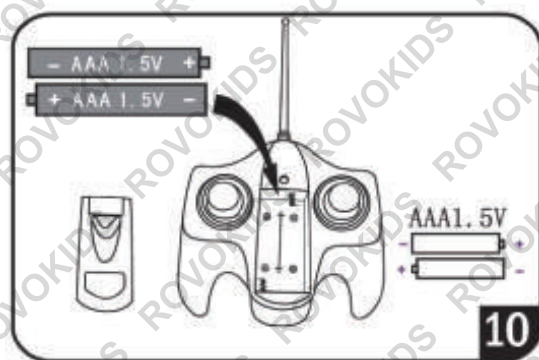

Kids Ride-on Car

5. Press the switch on the steering control; many kinds of music and sounds are available.

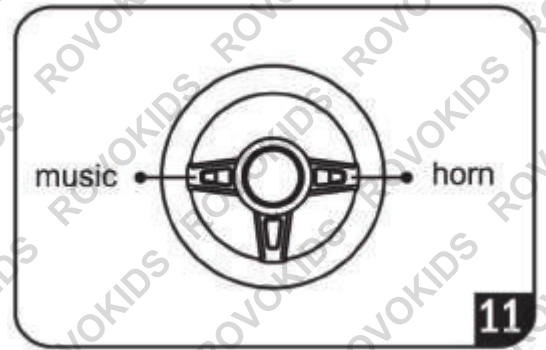

6. The car has a self-recovering safety wire. When the electric current is over 20A, it will cut the power after 5-10 seconds, and it can recover by itself.

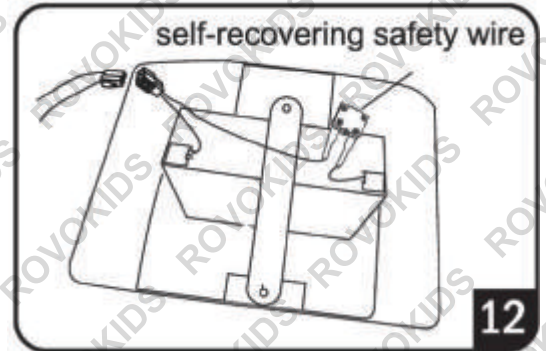



Kids Ride-on Car

Maintenance

- In order to keep your child away from accidents & injuries, please check and maintain the car regularly.
- Make sure that all parts are complete before installation.
- Please check periodically whether the screws are loose or the accessory parts are damaged.
- Make sure that every part is complete before installation and use.
- Please clean the car regularly; do not let the electrical device be damaged.
- Please install and disassemble the car according to the instructions to avoid causing any unnecessary damage.
- Please check the car and the charger regularly to make sure that the electrical wires, plug and other parts are not damaged. If any damages has been found, stop usage & repair immediately.

Technical Specifications

Item	Specifications
Battery	12V (2x 6v) / 7Ah
Battery type	Acid Lead
Suitable ages	37-96 months
Max loading weight	30 KG
Size	1250x700x510 mm
Utility time	8-12h (charge), 1-2h (use)
Charger	AC220V, 50Hz (input)



Some experts believe that the incorrect or prolonged use of almost any product may cause serious injury or death. To help reduce your risk of serious injury or death, refer to the information below. For more information, see www.datastreamserver.com/safety

- Consult all documentation, packaging and product labelling before use. Note that some products feature documentation available online. It is recommended to print and retain the documentation.
 - Before each use, check the product for loose/broken/damaged/missing parts, wear or leaks (if applicable). Never use a product with loose/broken/damaged/missing parts, wear or leaks.
 - Products must be inspected and serviced (if applicable) by a qualified technician every 6 months. This is based on average residential use by persons of average size and strength, and on a property of average metropolitan size. Use beyond these recommendations may require more frequent inspections/servicing.
 - Ensure that all users of the product have completed a suitable industry recognised training course before being allowed access to the product.
 - If this product has been purchased in error when considering the information presented here, contact the retailer directly for details of their returns policy, if required.
- The product has been supplied by a general merchandise retailer that may not be familiar with your specific application or description of application. Be sure to attain third-party approval from a qualified specialist for your application before use, regardless of any assurances from the retailer or its representatives.
 - This product is not intended for use where fail-safe operation is required. As with any product (for example, automobile, computer, toaster), there is the possibility of technical issues that may require the repair or replacement of parts, or the product itself. If the possibility of such failure and the associated time it may take to rectify could in any way inconvenience the user, business or employee, or financially affect the user, business or employee, then the product is not suitable for your requirements. This product is not intended for use where incorrect operation or a failure of any kind, including but not limited to, a condition requiring product return, replacement, parts replacement or service by a technician may cause financial loss, loss of employee time or an inconvenience requiring compensation.



©2018 Rovo Kids. All rights reserved. No part of this document, including descriptive content, concepts, ideas, diagrams or images may be reproduced or transmitted in any form or by any means, electronic or mechanical, including photocopying, scanning or recording, or any information storage and retrieval system, without express permission or consent from the publisher.