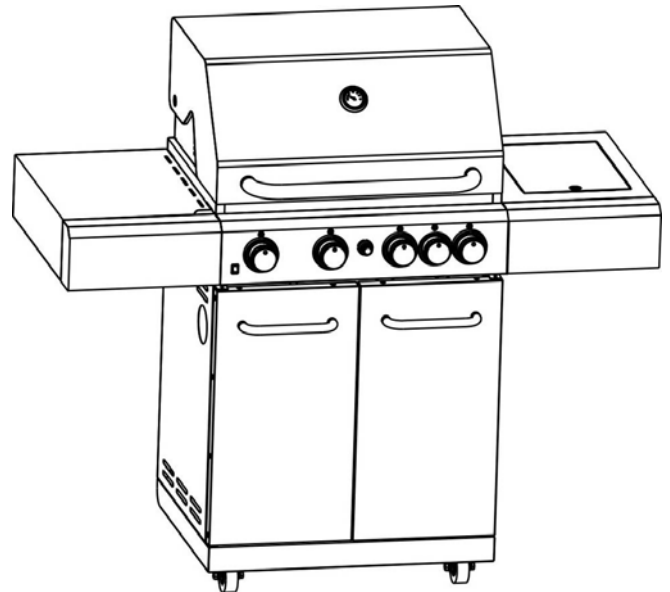

- FOR OUTDOOR USE ONLY.
  
- READ THE INSTRUCTIONS CAREFULLY AND BE SURE YOUR BARBECUE IS IN PROPERLY INSTALLED AND ASSEMBLED. FAILURE TO FOLLOW THESE INSTRUCTIONS MAY RESULT IN SERIOUS INJURY OR DAMAGE.
  
- PLEASE RETAIN THE MANUAL FOR FUTURE REFERENCE.
  
- CONVERSION OF NATURAL GAS ONLY TO BE DONE BY AUTHORIZED PERSONS.
  
- REMOVAL OF ANY TRANSIT PROTECTION BEFORE USING

**NOTE TO INSTALLER:**

**TEST OPERATION OF THE APPLIANCE AND INSTRUCT THE USER BEFORE LEAVING.**

**COKBBQEUGABR5**

## USE OUTDOORS ONLY

This appliance shall only be used in an above ground open-air situation with natural ventilation, without stagnant areas, where gas leakage and products of combustion are rapidly dispersed by wind and natural convection.

Any outdoor enclosure in which the appliance is used shall comply with one of the following:

- An enclosure with walls on all sides, but at least one permanent opening at ground level and no overhead cover. See Figure 1.
- Within a partial enclosure that includes an overhead cover and no more than two walls. See Figure 2 & 3.
- Within a partial enclosure that includes an overhead cover and more than two walls, the following shall apply:
  - At least 25% of the total wall area is completely open; and
  - At least 30% of the remaining wall area is open and unrestricted. See Figure 4 & 5.
- In the case of balconies, at least 20% of the total of the side, back and front wall areas shall be and remain open and unrestricted.

The following diagrams provide a diagrammatic representation of outdoor areas. Rectangular areas have been used in these figures - the same principles apply to any other shaped area

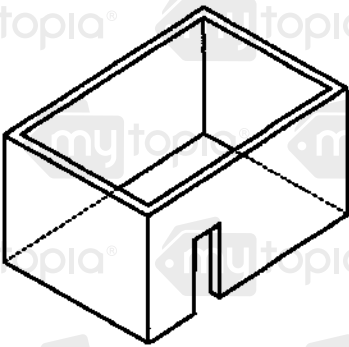

Figure 1 - Enclosure with walls on all sides but no overhead cover

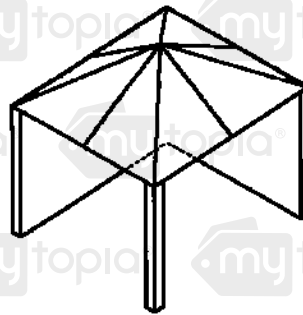

Figure 2 - Partial Enclosure with overhead cover and no more than two walls

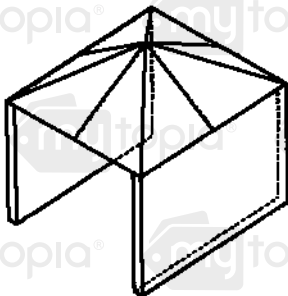
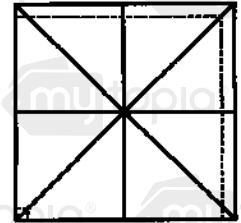

Figure 3 - Partial Enclosure with overhead cover and no more than two walls

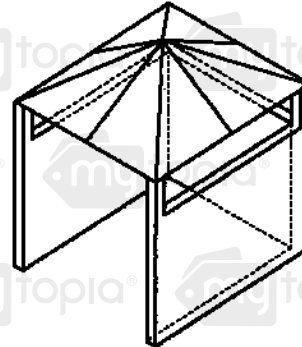
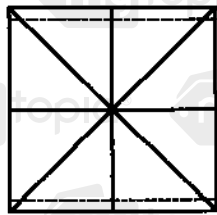

Figure 4 - Open side at least 25% of total wall area. 30% or more in total of the remaining wall area is open and unrestricted.

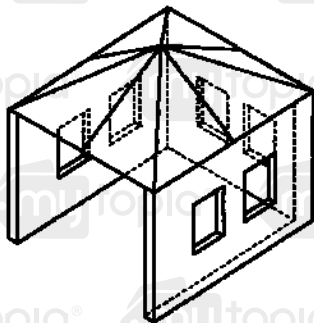
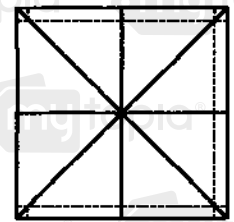
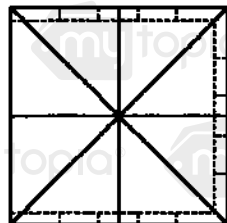

Figure 5 - Open side at least 25% of total wall area. 30 percent or more in total of the remaining wall area is open and unrestricted



## GAS CYLINDER INFORMATION



- This appliance is designed to be used with a gas cylinder not exceeding (Australia 9KG)
  - The gas cylinder supply valve must be turned off when the appliance is not in use.
  - Gas cylinders must be stored outdoors, out of reach of children and must not be stored in a building, garage or any other enclosed area.
  - The gas cylinder used must incorporate a safety collar to protect the valve assembly.
- \* Never store a spare cylinder under the barbecue shelves or inside the trolley housing. Any LPG cylinder not attached to the BBQ for use should be stored outdoors and well away from this appliance.

### Important:

- When disconnecting and removing the gas cylinder for the purpose of refilling, always observe the following procedure.
- Ensure that all gas control valves on the appliance and the gas cylinder are turned off before disconnecting the regulator from the cylinder.
- Do not smoke or use a naked flame near the appliance or gas cylinder while disconnecting the gas line between the appliance and gas cylinder.
- Remove the gas cylinder from the enclosure before disconnecting the regulator from the appliance.
- Tighten all connections before placing the gas cylinder back in its enclosure.
- The gas leak testing procedure should be conducted every time the gas cylinder is refilled and reconnected to the appliance before using the appliance.

### Regulator Connection

1. Check that all control knobs are in the 'Off' position.
2. Make sure the cylinder valve is off.
3. Remove the protective cap from the cylinder if present.
4. Leak test the connection with a soapy water solution.

### Gas Leak Test Procedure

Never use a naked flame to check for gas leaks.

Always use the following procedure to check for gas leaks.

1. In a small container, mix up a solution of water and detergent or soap. Mix the solution well.
2. Make sure that the gas supply valve on the gas cylinder is turned on.
3. Make sure that the gas control valves on the appliance are all turned off.
4. Using a brush or spray bottle apply the solution to the gas line and each join in the gas line.
5. Bubbling of the solution will indicate that there is a leak present.
6. Re-tighten or re-seal any joints that are leaking.
7. If a leak persists then contact your distributor or the manufacturer for assistance.

### AUS Standard POL Regulator

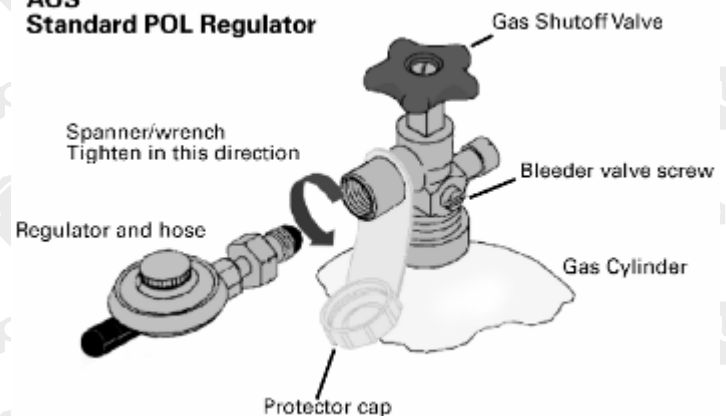

## LIGHTING YOUR BARBECUE

This barbecue is designed for use outdoors, away from any flammable materials.

It is important that there are **no overhead obstructions** and that there is a minimum distance of 1000mm from the side or rear of the appliance.

It is important that the ventilation openings of the cylinder compartment are not obstructed.

The barbecue must be used on a level, stable, non-flammable surface.

The appliance should be protected from direct draughts and shall be positioned or protected against direct penetration by any trickling water (e.g. rain). Parts sealed by the manufacturer or his agent must not be altered by the user.

No modifications should be made to any part of this barbecue and repairs and maintenance should only be carried out by a registered service engineer

**DO NOT** let children operate or play near grill.

**DO NOT** use charcoal or ceramic briquets in a gas grill

**DO NOT** light or use the side burner with the lid in the closed position.

**DO NOT** attempt to light burner with lid closed. A buildup of non-ignited gas inside a closed grill is hazardous

The side burner is designed for pot/pan with diameter 60-260mm. Side burner lid can not be used as work table, do not put anything on the side burner lid while it is not working

### -Lighting the Appliance

1. Open the lid and make sure all the knobs are on the OFF position.
2. Push down the knob and turn the knob anticlockwise to HIGH position, then keep pressing the igniter for 2-3 seconds ( a sound could be heard), thus the burner could be lit. If the burner does not light, turn off the knob and wait for 5 minutes then repeat this process.
3. Adjust the heat by turning the knob to the High /Low position.
4. To light other burners, repeat the same process for the adjacent burner and continue in sequence until all the burners are lit.
5. To turn the barbecue OFF, turn the cylinder valve or regulator switch to the "OFF" position and then turn all of the control knobs on the barbecue clockwise to the "OFF" position.

The side burner is designed for pot/pan with diameter 180-260mm. Side burner lid can not be used as work table, do not put anything on the side burner lid while it is not working

Before cooking for the first time, light on all the main burners and keep burning for 15 minutes with the lid closed and knob at HIGH position . This will "heat clean" the internal parts and dissipate odor from the painted finish. The color of cooking area may get little change. It is normal and it is the nature of material.

## **⚠ WARNING**

While igniting main burner and infrared rear burner, please make sure the lid for main burner is in open situation

While igniting side burner, please make sure the lid for side burner is in open situation

While cooking with the hood closed and with all the burners on, please make sure all these burners in LOW flame position.

## **CLEANING AND CARE**

All cleaning and maintenance should be carried out when the barbecue is cool and with the fuel supply turned **OFF** at the gas cylinder after each time use.

**DO NOT** mistake brown or black accumulation of grease and smoke for paint. Interiors of gas grills are not painted at the factory (and should NEVER be painted). Apply a strong solution of detergent and water or use a grill cleaner with scrub brush on insides of grill lid and bottom. Rinse and allow to completely air dry.

**DO NOT** apply a caustic grill / oven cleaner to painted surfaces.

**DO NOT** use abrasive or flammable cleaners, as it will damage the parts of the product and may start a fire.

**Stainless steel surfaces:** Stainless steel would get rust if not maintain well. To maintain your grill's high quality appearance, wash with mild detergent and warm soapy water and wipe dry with a soft nonabrasive cloth after each use.

**Cooking grid:** Use a mild soapy water solution. Non-abrasive scouring power can be used on stubborn stains then rinse with water.

### **Cleaning the burner assembly**

Follow these instructions to clean parts of burner assembly or if you have trouble igniting grill.

1. Turn gas off at control knobs and LP Tank.
2. Remove cooking grates, grease tray and grease cup.
3. Remove screw at end of burner using a screwdriver.
4. Carefully lift each burner up and away from valve openings.
5. Wire brush entire outer surface of burner to remove food residue and dirt.
6. Clean any blocked ports with a stiff wire such as an open paper clip.
7. Check burner for damage, due to normal wear and corrosion some holes may become enlarged. If any large cracks or holes are found replace burner.
8. Carefully refit burners.
9. Replace screw at the end of burner.
10. Replace grease tray and cooking grates.

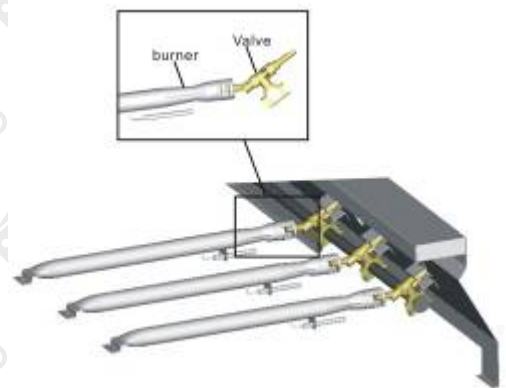

Inspect burner for any damage (cracks or holes). If damage is found, replace with a new burner. Reinstall the burner, check to ensure that the Gas valve orifices are correctly positioned and secured inside the burner inlet.

We suggest following ways to clean the burner tubes.

(A) Bend a stiff wire (a light weight coat hanger works well) into a small hook. Run the hook through each burner tube and burner several times.



(B) Use a narrow bottle brush with a flexible handle (DO NOT use a brass wire brush), run the brush through each burner tube and burner several times.

(C) Wear eye protection: use an air hose to force air into the burner tube and out the air ports. Check each port to make sure air comes out each hole.

**CAUTION**

**NATURAL HAZARD SPIDERS**

FACT: sometimes spiders and other insects climb into the grill tubes attached to the burners. The spiders spin webs, build nests and lay eggs. The webs or nests can be very small, but they are very strong and can block the flow of gas.

Clean burners prior to use after storing, at the beginning of grilling season or after a period of one month not being used.

Spider guards are on the air intakes in an effort to reduce this problem, but it will not eliminate it! An obstruction can result in a “flashback” (a fire in the burner tubes). The grill may still light, but the obstruction does not allow full gas flow to the burners.



**Abnormal Operation:**

Any of the following are considered to be abnormal operation and may require service

- Yellow tipping of the yellow flame
- Sooting up of grills plates
- Burners not igniting properly
- Burners failing to remain alight
- Burner extinguished by trolley doors
- Gas valves, which are difficult to turn

## Technical Information

**Model No.** COKBBQEUGABR5

**Gas Type:** Universal LP Gas & Natural Gas

**Test Point Pressure:** Universal LP Gas- 2.75KPA

Natural Gas-1.0KPA

**Total Nominal Gas Consumption:** Universal LP Gas-63MJ/h

Natural Gas-57MJ/h

**Nominal Gas Consumption & Injector size:**

Universal LP Gas - Main Burners: 13MJ/h x 4

Injector size 0.98mm

- Side Burner: 11MJ/h

Injector size 0.98mm

Natural Gas - Main Burners: 11MJ/h x 4

Injector size 1.50mm

- Side Burner: 11MJ/h

Injector size 1.65mm

**AGA Approval No:**

**Note:**

-For Use outdoors only

-Conversion of natural gas only to be done by authorized person

-The minimum cylinder size for use with this appliance is 7kgs

-The thread type of this appliance is G1.4B.

## ASSEMBLY INSTRUCTIONS

### Tools required:

1. Philips Screwdriver
2. Gloves ( if necessary)

### EXPANDED VIEW

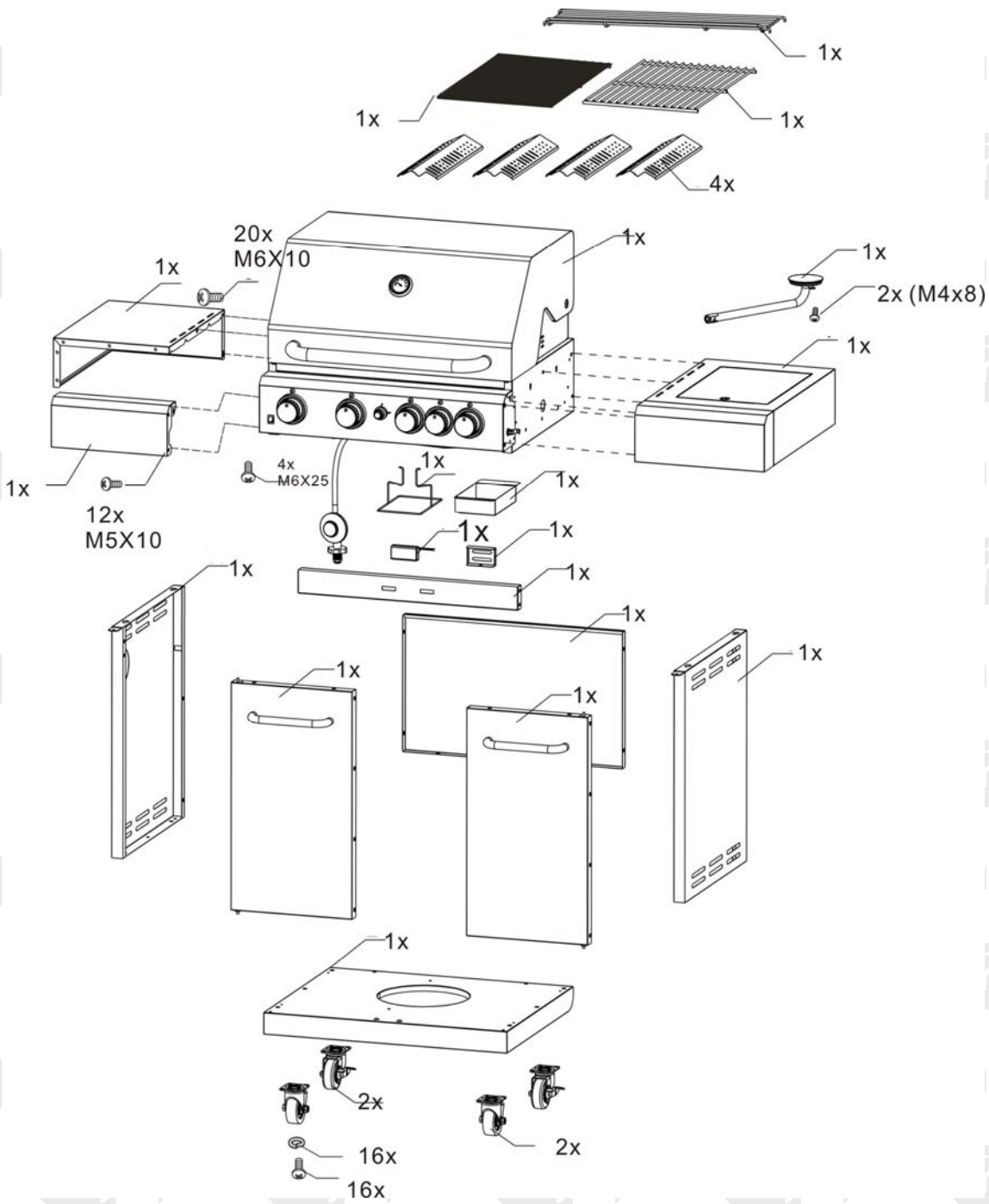



**1.** Note: Screws being preassembled. Please unscrew then assembly

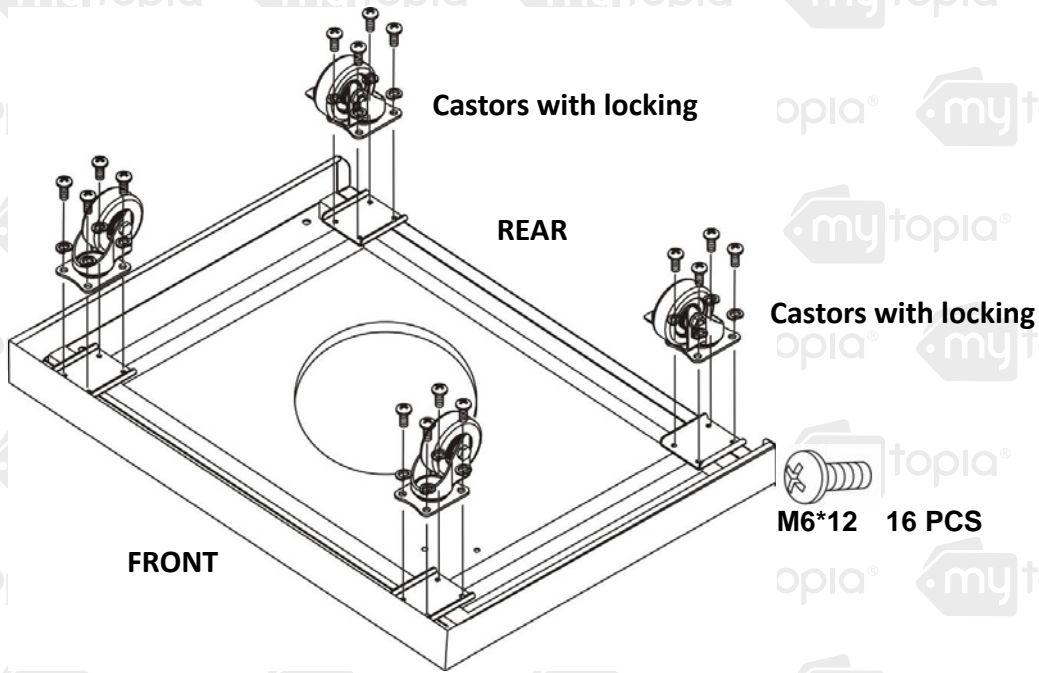

**2.**

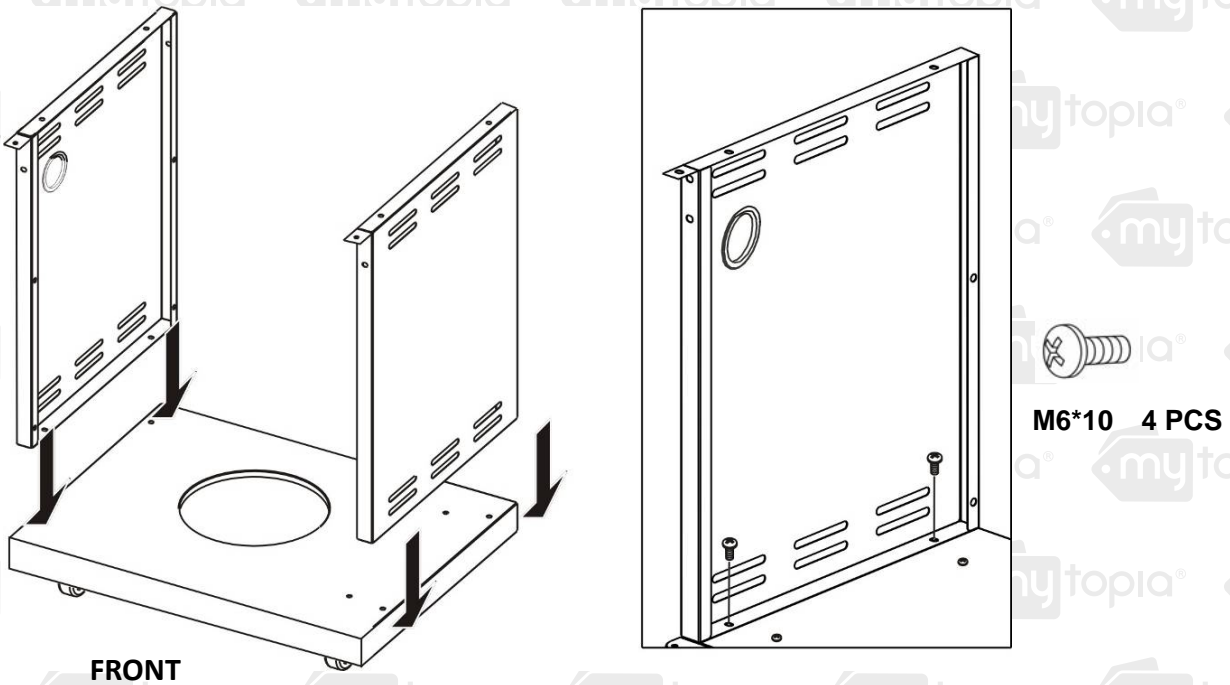

3.

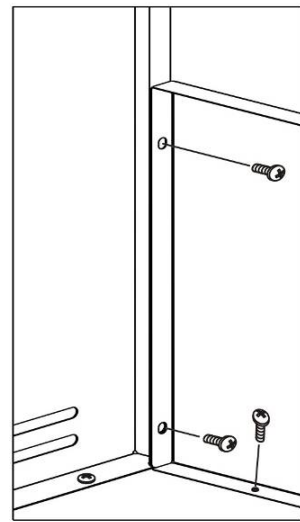
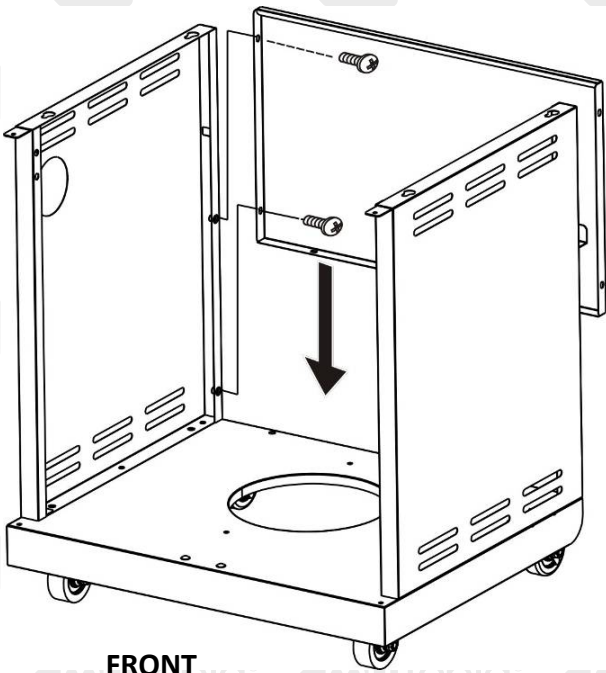

M6\*10 6PCS

4.

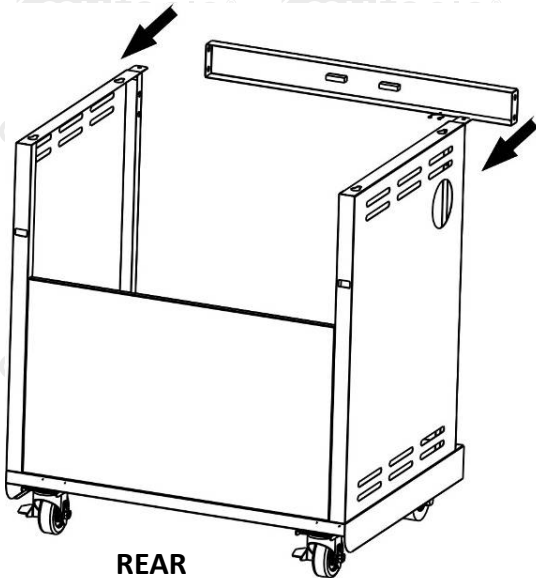

M6\*10 4 PCS

**5.** 2xAA battery for LED light

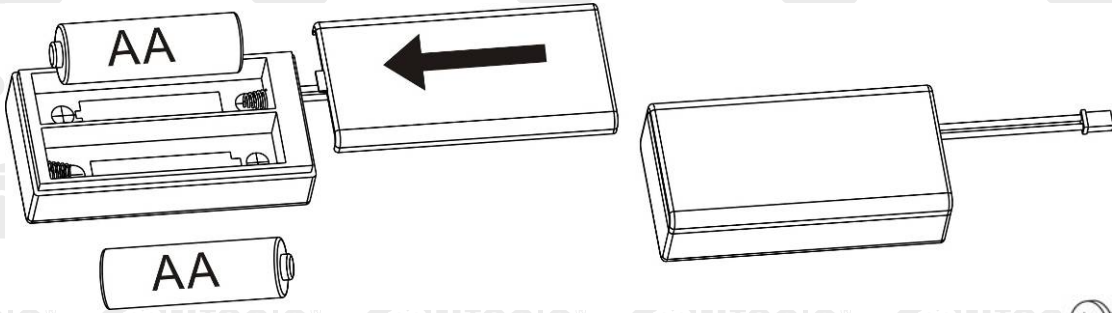

M5\*10 1 PC 

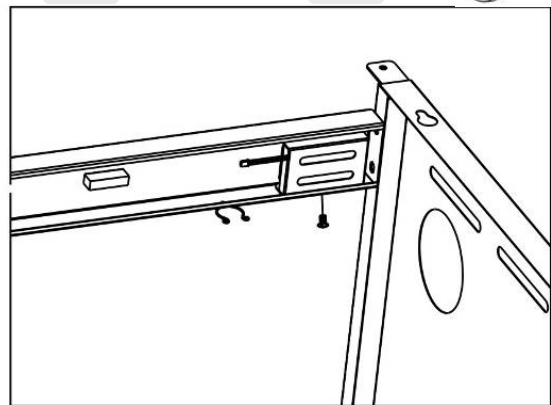
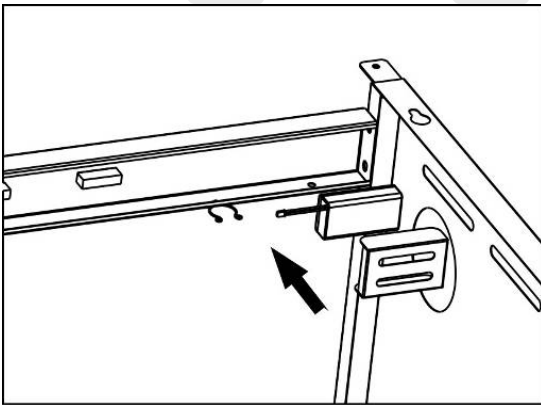

**6.**

Spring loaded pivot pin

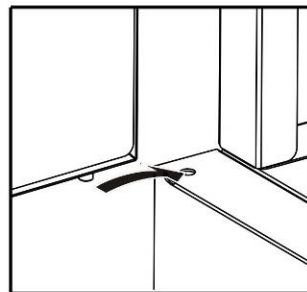
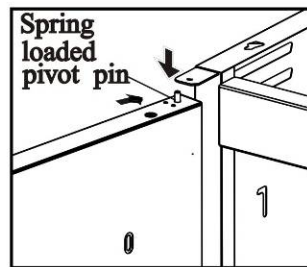
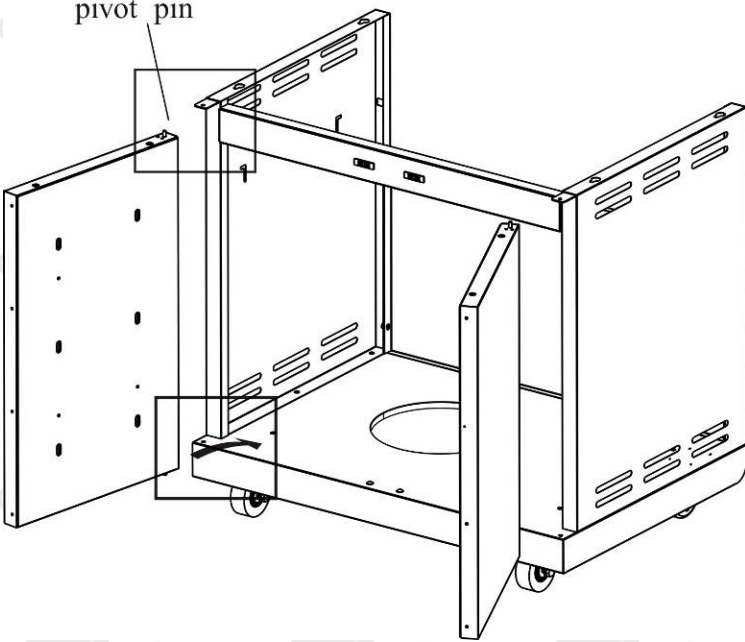

7.

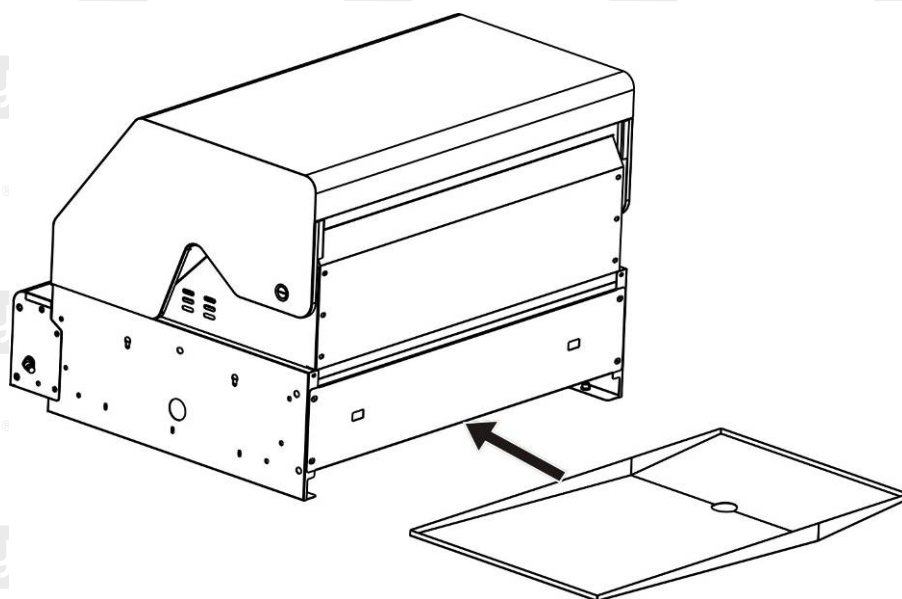

8. NOTE: It requires 2 persons to lift with gloves.

After assembling, the screws could stop the grease tray sliding out.

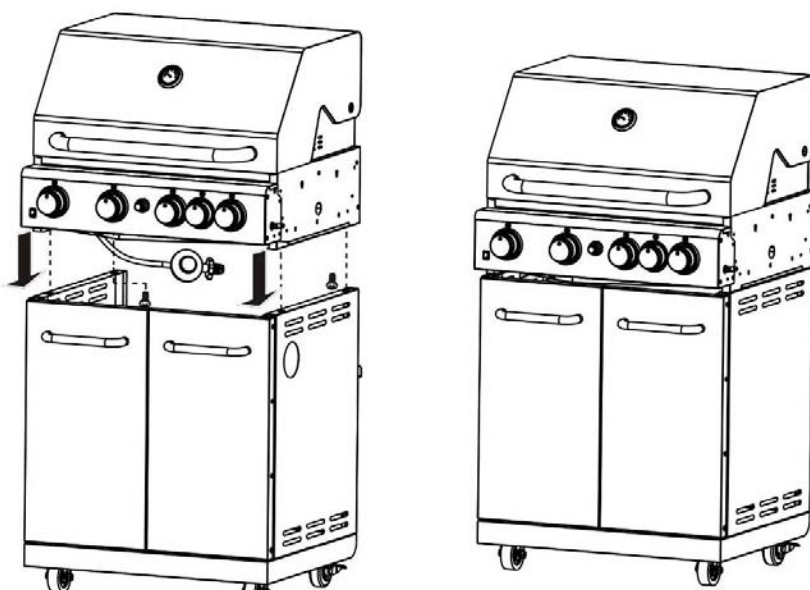

M6\*25 4 PCS

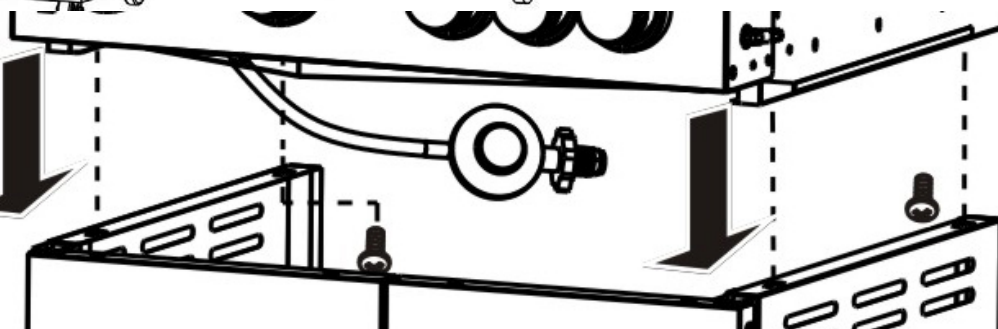

9.

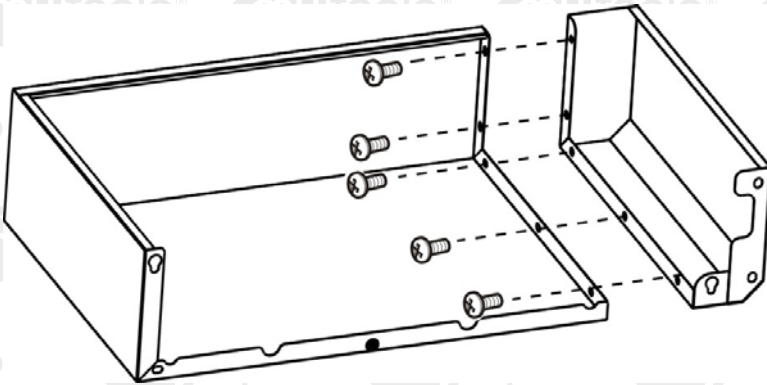

M5\*10 5 PCS

10.

NOTE: Be careful for the sharp edge.

Please use the long Philip Screwdrivers for easy operation.

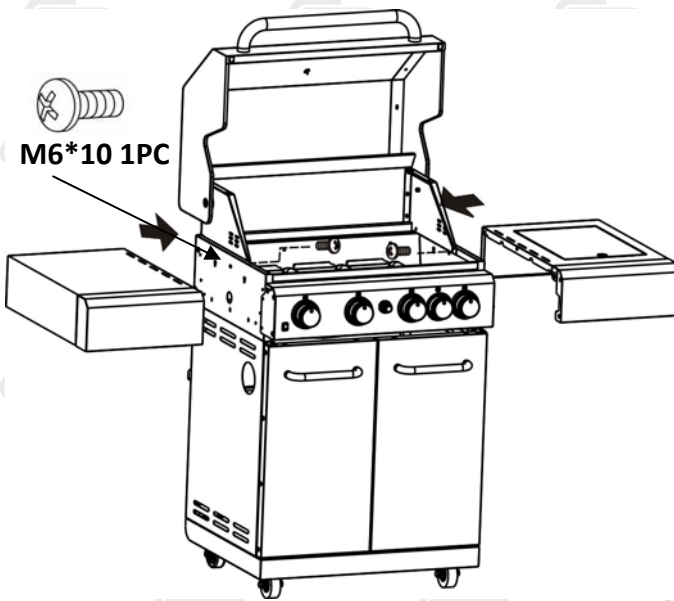

M6\*10 1PC

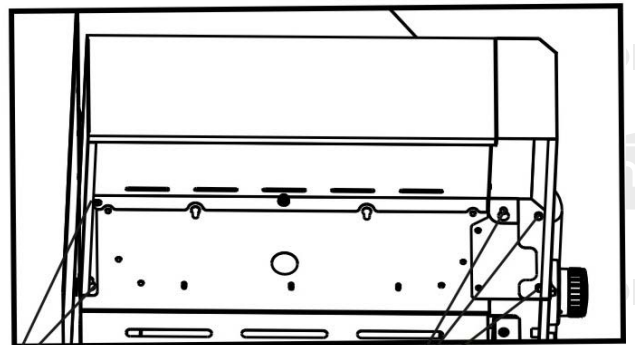

M6\*10 4PCS

M5\*10 6 PCS

10.

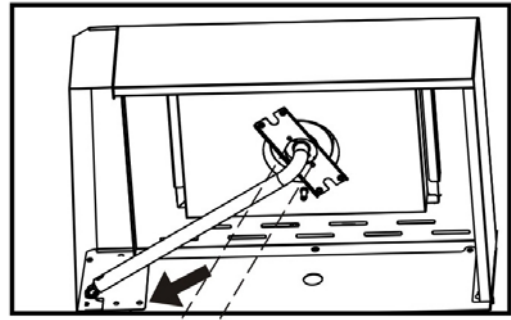
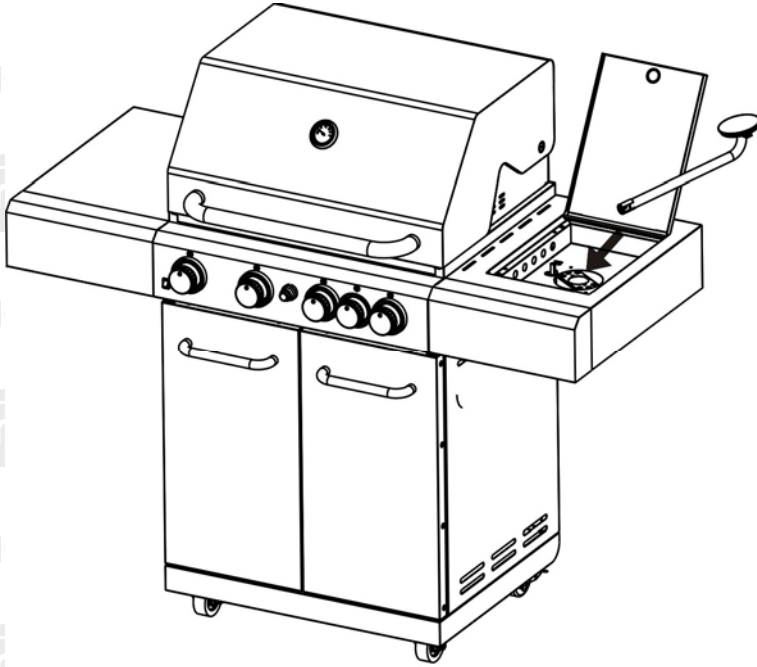

**NOTE:** make sure the side burner connector well insert into the side burner tube.

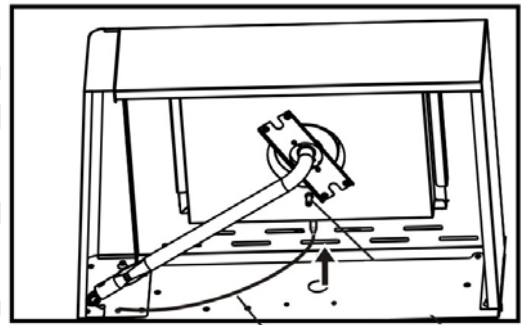

**NOTE:** Attached the ignition wire to the ignition lead

11.

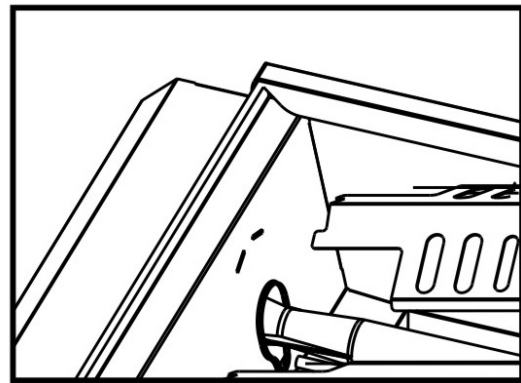
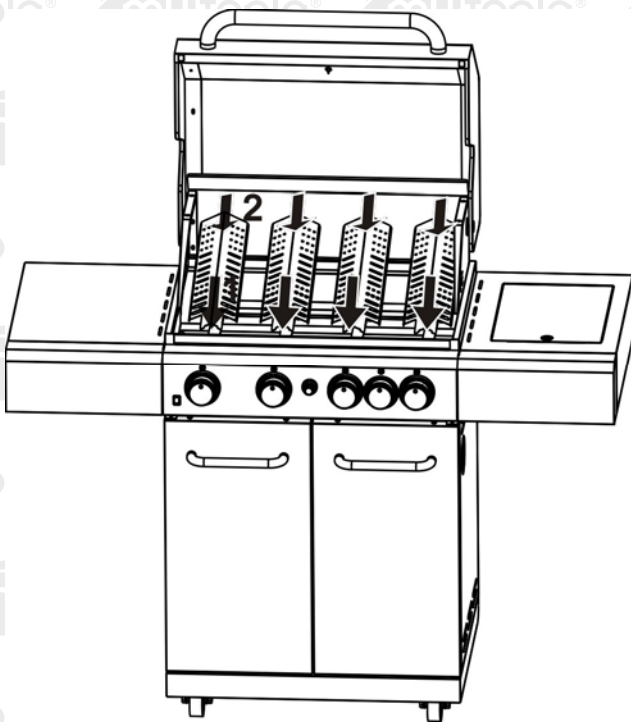

12.

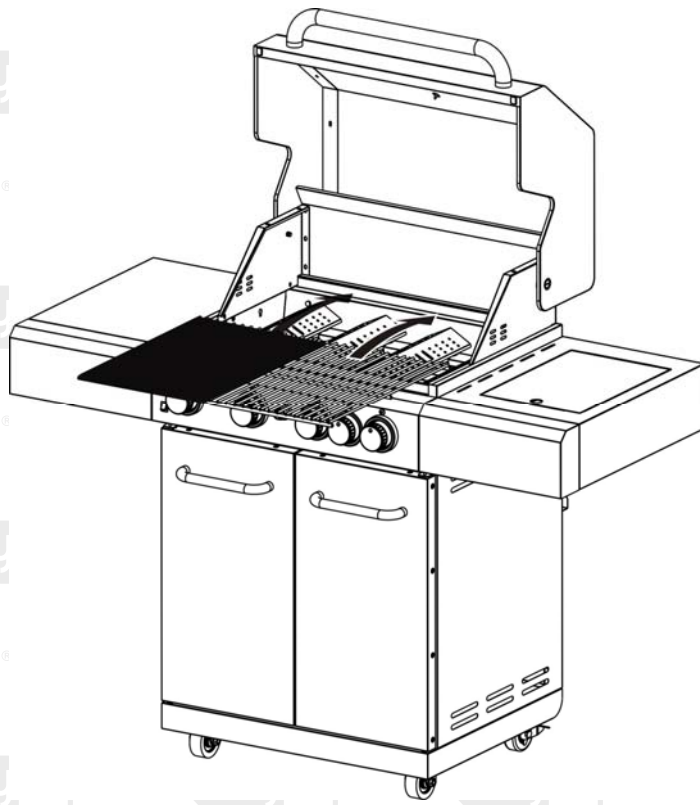

13.

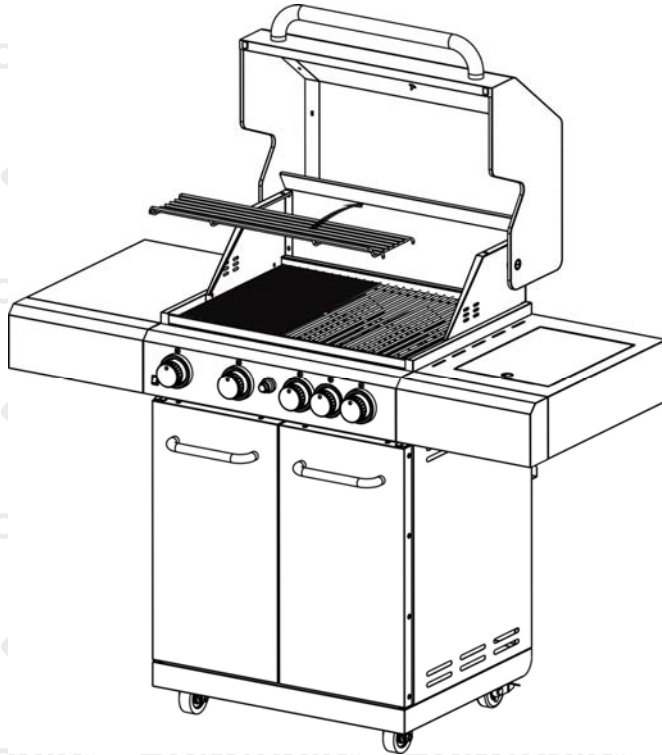

**14. NOTE:**

A hook is fixed to tighten the gas hose to avoid the chance to touch the high temperature parts like grease tray.

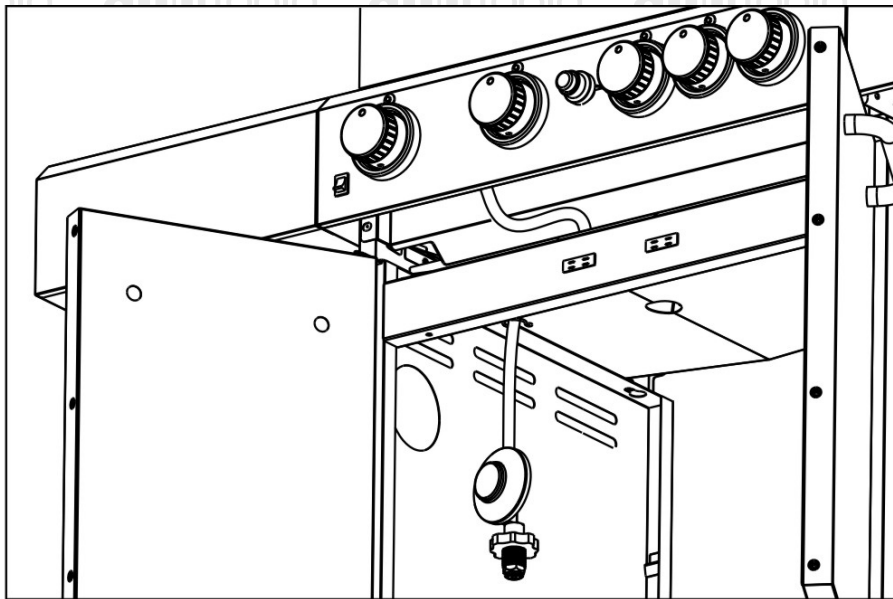
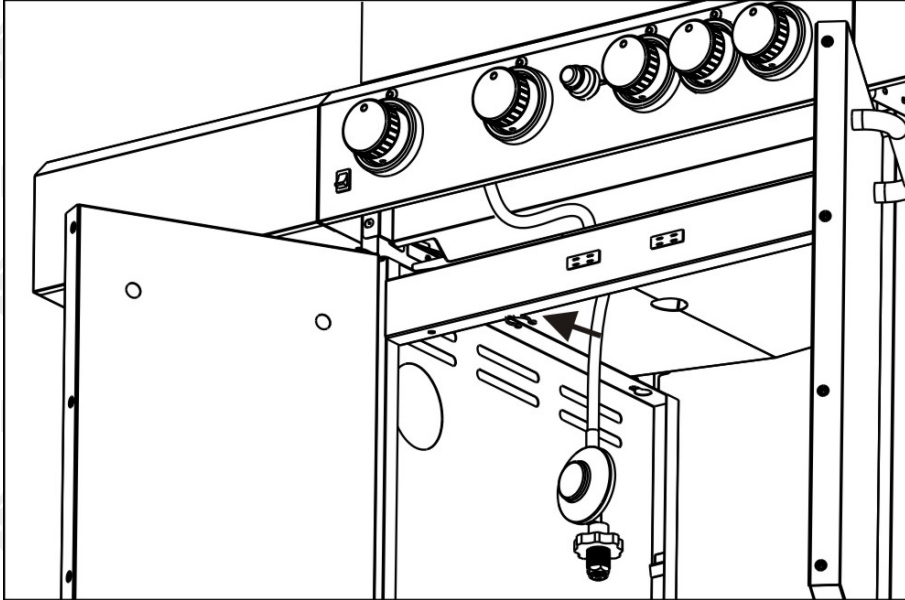



**15. Connect the led cable to battery box**

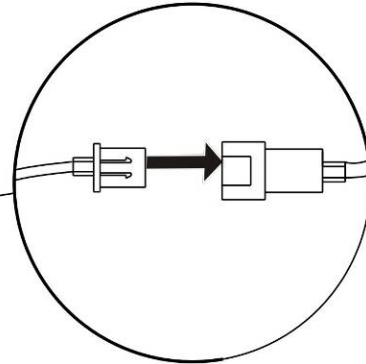
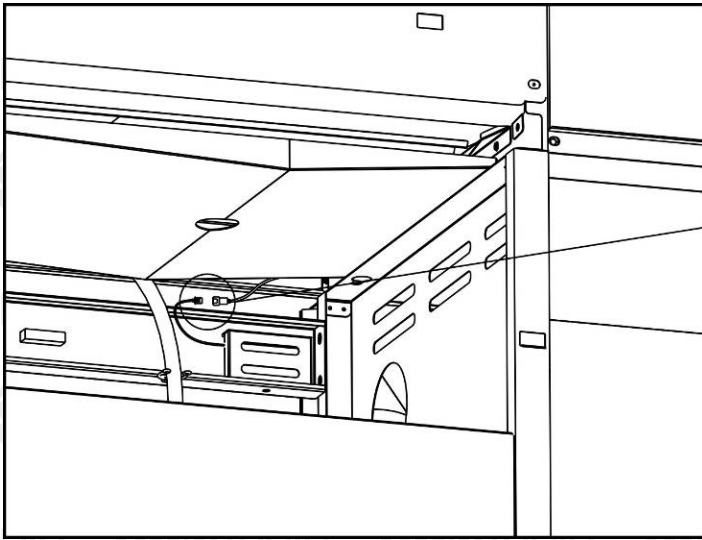

**16.**

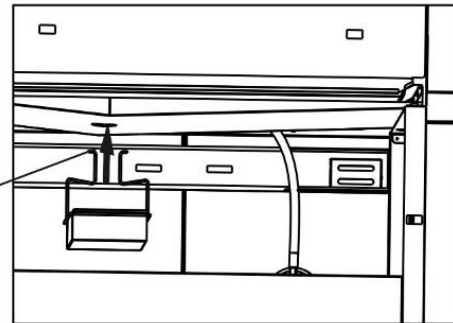
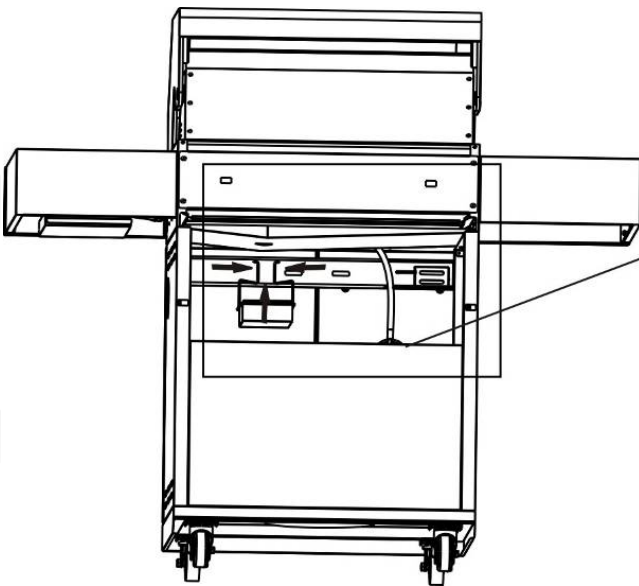

## Natural Gas Conversion

**⚠ WARNING** CONVERSIONS ONLY TO BE DONE BY AUTHORIZED PERSON

### Tools required

1. Socket head set screw driver (Included with the product)
2. Wrench



### Gas Piping

1. A minimum pipe with diameter 15mm is required for inlet piping. A lever operated shut-off valve should be installed with 1 meter of the appliance for serving the appliance.
2. Where is not practical to install solid tube AGA certified to AS/NZS 1869 class A, stainless steel braided hose could be installed. This hose assembly must comply with AS5601 Gas installations, pipe sizing tables and shall not exceed 3 meters in length. The internal diameter of the hose must not be less than 10mm.
3. All gas pipe connection must be sealed with a gas pipe compound resistant to natural gas.

### NOTE TO INSTALLERS

1. The U-LPG injector is 0.98mm, the NG injector is 1.50mm.  
The BBQ is equipped with jets for both LPG on.



2. The BBQ is set for U-LPG by manufacturer.
3. Please follow following instructions to converse from LP to NG

### \* Instructions for converting the main burners

1. Unscrew and remove the rear panel pictured.



2. Unscrew the main burner securing screws and remove the burner sitting it just beside.



3. With the burner removed, you will see the brass gas jet which is screwed into the end of the valve. Using the socket driver supplied, unscrew the end LPG jet while retaining the inner (NG) jet.

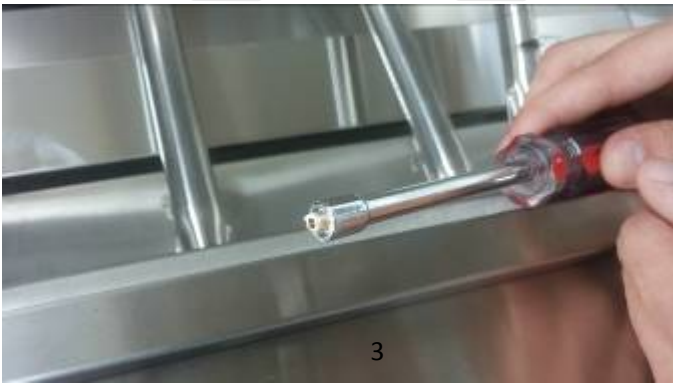
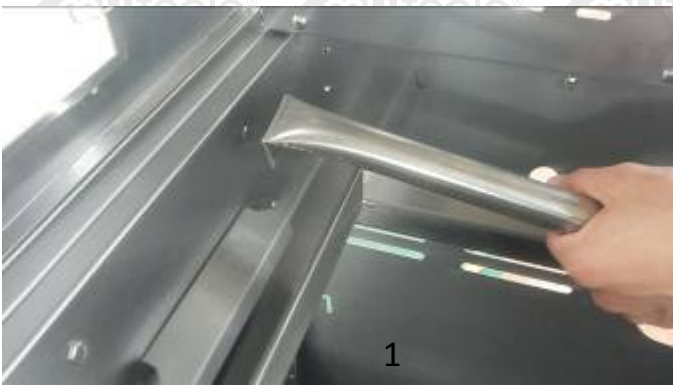

4. Reassemble the burner.

**Note:** Please make sure the gas valve is located well inside the main burner tube when re-installing the burners.

5. Repeat the above steps for the other main burners

**\* Instructions for converting the side burner**

1. Remove the side burner ignition wire and take away the side burner



2. Using the supplied socket screwdriver, unscrew and remove the LPG gas jet, leaving the NG jet in place.



3. Reassemble the side burner.

**Note: Please make sure the gas valve is located well inside the main burner tube.**



**Some experts believe the incorrect or prolonged use of almost any product could cause serious injury or death. For information that may reduce your risk of serious injury or death consult the points below and additionally, the information available at [www.datastreamserver.com/safety](http://www.datastreamserver.com/safety)**

- Consult all documentation, packaging and product labelling before use. Note that some products feature online documentation which should be printed and kept with the product.
- Check product for loose / broken / damaged / missing parts, wear or leaks (if applicable) before each use. Never use a product with loose / broken / damaged / missing parts, wear or leaks (if applicable).
- Products must be inspected and serviced (if applicable) by a qualified specialist every 6 months assuming average residential use by a person of average weight and strength, above average technical aptitude, on a property matching average metropolitan specification. Intended use outside these guidelines could indicate the product is not suitable for intended use or may require more regular inspection or servicing.
- Ensure all possible users of the product have completed an industry recognised training course before being given access to the product.

- The product has been supplied by a general merchandise retailer that may not be familiar with your specific application or your description of the application. Be sure to attain third party approval for your application from a qualified specialist before use regardless of prior assurances by the retailer or its representatives.
- This product is not intended for use where fail-safe operation is required. As with any product (take an automobile, aircraft, computer or ball point pen for example) there is always a small chance of a technical issue that needs to be repaired or may require replacement of the product or a part. If the possibility of such failure and the associated time it takes to rectify could in any situation inconvenience the user, business or employee or could financially affect the user, business or employee then the product is not suitable for your requirements. This product is not for use where incorrect operation or a failure of any kind, including but not limited to a condition requiring product return, replacement, service by a technician or replacement of parts could cause a financial loss, loss of employee time or an inconvenience requiring compensation.
- If this item has been purchased in error considering the points above simply contact the retailer directly for details of their returns policies if required.

